

Why Did the Snake Cross the Road?

A Population Genetics and Habitat Conservation Case Study

by

Milton T. Drott and Mark A. Sarvary

Introduction

In the United States, painters like Thomas Cole (1801–1848) captured natural beauty in paintings, often removing marks of human intervention from their landscapes. Although an appreciation for unadulterated natural landscapes is not a new development in human history, with conservationist ideas appearing even in ancient texts, the modern conservation movement did not start until the mid-19th century. This movement marked a shift from attempts to recreate and harness nature, as in the creation of New York City's Central Park (1857), to the preservation of natural landscapes with the creation of the first National Park, Yellowstone (1872).

Despite legal efforts to preserve nature, extinctions have continued. Aldo Leopold (1947), considered by some the father of wildlife conservation, wrote about the extinction of the passenger pigeon, once the most abundant bird in North America:

"We grieve because no living man will see again the onrushing phalanx of victorious birds, sweeping a path for spring across the March skies, chasing the defeated winter from all the woods and prairies of Wisconsin. . . . Our grandfathers were less well-housed, well-fed, well-clothed than we are. The strivings by which they bettered their lot are also those which deprived us of pigeons. Perhaps we now grieve because we are not sure, in our hearts, that we have gained by the exchange. The gadgets of industry bring us more comforts than the pigeons did, but do they add as much to the glory of the spring?"

In addition to the fundamental appreciation and perhaps a moral sense of stewardship over nature that Leopold's words convey, conservation is a practical movement. Today, continued deforestation, land conversion, and development continue to threaten wildlife. These processes not only destroy available habitat, but fragment the landscape, turning the lush ocean of natural ecosystems into small islands between developed areas. A study by Haddad et al. (2015) found that such fragments lose half of their plant and animal species within twenty years. Even small human interventions like roads play a role in putting 70% of the world's forests within one kilometer of a fragment edge (Haddad et al., 2015).

E.O. Wilson has suggested that instead of conserving separate islands of natural landscape, we connect such areas by long uninterrupted corridors, creating a structure that would, in sum, cover half the earth. This would allow for interbreeding between otherwise isolated populations and would foster larger scale events important to wildlife's survival, such as migrations. For now, various countries, including the United States, Canada, and Australia, have attempted to connect otherwise fragmented areas using wildlife crossings. These crossings are either under or overpasses that allow wildlife to traverse from one fragment to another. While these interventions have been successful in many areas, their applicability is limited based on location and organism. Further work is needed to understand the best ways that conservation can develop such interventions to decrease the effect of landscape fragmentation.

Project Overview

Dr Zoltan Thury, a researcher in the Department of Investigative Biology at Cornell University, has long been interested in how biodiversity is generated and maintained in natural systems. His lab's efforts, spearheaded by graduate student Barbara Joy, are examining the role of anthropogenic change on population structuring of timber rattlesnakes (*Crotalus horridus*), specifically asking if roads of different widths have differential impacts on the genetic differentiation of populations in small fragments; this is also known as population subdivision. This case will guide you through the Thury lab's research for a pilot study that will serve as the basis of developing a grant proposal.



Figure 1: Geographic distribution of *Crotalus horridus* based on range data from Hammerson (2007). Credit: rbrausse, CC BY-SA 3.0, <https://commons.wikimedia.org/wiki/File:Crotalus_horridus_distribution.png>.

As shown in Figure 1, timber rattlesnakes have a geographically large range, and this, coupled with large populations within much of the range has led to their conservation classification of “least concern.” Although endangered in some areas, these venomous pit vipers have not been of real concern to conservationists. However, their range has decreased over the last few years, raising questions about the changing ecology of the eastern United States. Part of this decrease may be related to land development. Creation of buildings and roads has the potential to restrict migration, increasing the probability of mating among close relatives. Thus the whole population of *C. horridus* may be becoming more inbred, even if the population size is not, initially, numerically smaller. Furthermore, *C. horridus* migrates from overwintering dens to nearby forested lands to mate, and thus is particularly vulnerable if its path is blocked.

A recent Cornell University survey has determined that roads divide the local area's population of timber rattlesnakes. The university has received a federal grant to support conservation research and has decided to create a program to build two underpasses allowing wildlife to pass under the roads that divide the local population of *C. horridus*. In addition to aiding in conservation, the underpasses will also allow for future research into the effectiveness of such interventions in mitigating the effects of roads on natural populations. Teams of undergraduates are being encouraged to apply for a prestigious funding award that contributes to a phase of this research.

You decide that obtaining this funding would be valuable to have on your resume and suggest to your group that you all have a real shot of winning this grant. Your team decides to apply.

After applying, all teams are given access to lab/field supplies in order to carry out a small-scale study in preparation of the larger experiment. Such preliminary studies, often called pilot studies, are frequently used in science to make sure that a full-scale experiment is worth doing. After completing the pilot study, your team will communicate your findings to the Thury lab. Based on the results of the pilot study, Dr. Thury will decide which team can continue on to the full-scale study.

Getting Started

Trying to figure out where to start a research project is often difficult. You start off by realizing that, to determine the effects of the local roads on the population of *C. horridus*, you will need to compare the current state of the snake population to the state of such a population where the roads have no effect. Luckily, you remember that you have had some introduction to how populations function in Hardy-Weinberg equilibrium (HWE). If the road is affecting population structure, then either side of the road may act more like a separate population, meaning that analyzing both together will cause deviations from what you would expect in HWE. You decide to use what you know about genotype frequencies of populations in HWE as the basis for your analysis. Your next step is to meet with your group to review HWE by considering the variables in it and deciding which aspects of your situation they represent. The variables are road width and degree of population subdivision.

First, your group needs to demonstrate that you have the necessary skills to tackle a problem in population genetics. In order to receive the information for the preliminary study, you have to answer the following questions about HWE.

- 1.1 What does the group think are the most important assumptions of HWE for the system you are preparing to ask questions about?
- 1.2 Using the data provided below on a single location, demonstrate that you can calculate the expected (HWE) number of homozygotes and heterozygotes, as this is an important component of understanding population structure. Please note: p is the frequency of allele “A” and q is the frequency of allele “a.”

	Observed number	Expected number	Expected frequency
AA	22		p^2
Aa	38		$2pq$
aa	20		q^2

p =

q =

Calculations:

Notify the instructor when you are ready to submit the answers before moving on to the pilot study.

Pilot Study

Now that you have briefly reviewed HWE, you are ready to complete the first step of your grant application: to execute a pilot study and to interpret data from it. When you demonstrate that you can collect and analyze data, you will be eligible to apply for the grant.

2.1 Generally when developing such preliminary studies, the most useful/practical design is the simplest one that will give the desired information. In the pilot study, you will sample two locations at two sites, one to the east and west of Interstate 81 (I-81) and one to the north and south of a secondary road connecting to I-81 (Figure 2).

State a research hypothesis for the pilot study:

State a prediction:

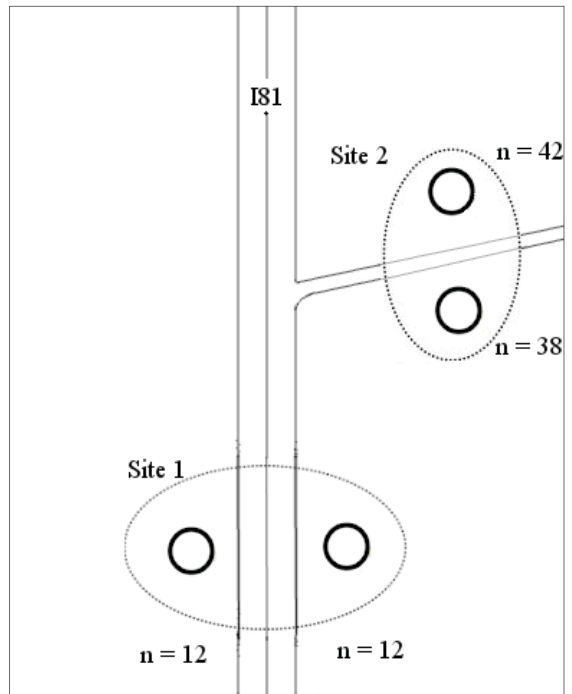

Figure 2. Map of the two sampling sites for the pilot study.

Loaded down with bite-proof boots and wielding snake-catching equipment (Figures 3 and 4) your group then collects tail-tip samples from 12 snakes from a location at the site west of I-81 and another 12 from the same site but at a location directly across on the eastern side of I-81. Your group then packs back into the car and travels to collect two batches of data from Site 2. You collect data from 42 snakes at Site 2 north, and from 38 snakes at Site 2 south.

2.2 With only a few small puncture wounds, your group returns home from the pilot study sites. A DNA extraction, followed by multiplex PCR to genotype, yields the following data for the two locations at Site 1:

	AA	Aa	aa
Site 1 West	12	0	0
Site 1 East	0	0	12

2.3 Your group now sits down together to discuss your study and to formulate a testable hypothesis. As you know, HWE defines a system that is not evolving. How is that useful to the situation you are looking at? That is, what



Figure 3. Snake catcher. Home-made snake catchers consist of a piece of rope creating a loop and threaded through PVC pipe. The loop is lassoed around the snake and then pulled tight to the PVC pipe. Photo credit: Susie Wyshak (with permission).



Figure 4. Snake pipe. A long tube that snakes are encouraged into; it is too narrow for a snake to turn around in, allowing for sampling. Photo credit: Tanith Tyrre (with permission).

is the specific question that you are using HWE to test? Write the null hypothesis of your analysis and explain how it relates to evolution.

- 2.4 What is the number of expected heterozygotes under HWE at Site 1 if you treat populations on both sides of I-81 as a single population?

Expected heterozygotes when treated as one population:

- 2.5 What is the total expected number of heterozygotes if you treat the east and west locations as two different populations?

Expected heterozygotes in each population:

- 2.6 Consider the difference made by how you define the population. What does it mean about the role of I-81 in this population's structure? Are you surprised?

- 2.7 Discuss with your group what your results from questions 2.4 and 2.5 mean for the applicability of HWE to the population you are studying. What are the implications for your hypothesis in 2.3?

Site 2

Now that you have discussed the results from Site 1, take a look at the data from Site 2 (given below).

Treated as one population:

Total: 35AA, 25 Aa, 20aa

Treated as separate populations:

	AA	Aa	aa
Site 2 North	28	12	2
Site 2 South	7	13	18

- 3.1 How do the data from Site 2 differ fundamentally from those from Site 1?
- 3.2 What are the implications of this difference on the population subdivision happening at Site 2?
- 3.3 Can you think of any possible ways to quantify population subdivision at your second site?

Now, make sure that all of the members of your group understand the results so far, as you will need to communicate them to other groups. Pick one member of your group who will switch with a member of the other group and summarize your findings so far. After the visiting group member has made sure that their host group is in agreement, they should return to their original group and continue the case.

*Request Help Sheet 1 from your instructor.
When you are finished reading Help Sheet 1, answer
questions 4 and 5 on the next page.*

- 3.4 Calculate the expected heterozygote frequency at Site 2 as though the road doesn't create two populations. Then calculate it as though the road creates two separate populations.

Treated as one population:

Total: 35AA, 25 Aa, 20aa

$$p =$$

$$q =$$

$$\text{Expected heterozygote frequency: } 2pq =$$

Treated as separate populations:

North side of road: 28 AA, 12 Aa, 2 aa

$$p =$$

$$q =$$

South side of road: 7 AA, 13 Aa, 18aa

$$p =$$

$$q =$$

Calculate the expected heterozygote frequency in subpopulations using the information you received from the graduate student:

What did you conclude based on these results?

Although you've now started to analyze your pilot study data, how might you assess population subdivision from this information? Submit your 3.4 calculations to the instructor to receive another correspondence from the kind graduate student who helped you before.

Request Help Sheet 2 from Instructor

Recalculate

- 4.1 Using the new information and formula from Help Sheet 2, recalculate the expected heterozygote frequency at Site 2, as you did in 3.4.

Treated as separate populations:

North side of road: 28 AA, 12 Aa, 2 aa

$$p =$$

$$q =$$

South side of road: 7 AA, 13 Aa, 18aa

$$p =$$

$$q =$$

What difference do you notice compared to your previous calculation in 3.4?

You should now be able to quantify the extent of population subdivision from the sites in your pilot study. Recall from section 3 that the Wahlund effect reduces expected heterozygosity within subpopulations (the numerator in F_{ST}) compared to the expected heterozygosity across the total population (the denominator in F_{ST}). The only time the number of heterozygotes will not be smaller in subpopulations (relative to the population when ignoring subdivision) is if the allele frequencies in subpopulations are equal ($p_1 = p_2$); in that case, the expected heterozygosity will be equal. With this in mind, calculate the F_{ST} value for Sites 1 and 2.

Site 1:

Site 2:

- 4.2 Interpret your F_{ST} results from the pilot study for Site 1 and Site 2. It may be helpful to first think about the maximum and minimum values of F_{ST} and what they mean:

Maximum:

Meaning of maximum:

Minimum:

Meaning of minimum:

Interpretation of Site 1 F_{ST} :

Interpretation of Site 2 F_{ST} :

Communicate

Now that you have collected data and interpreted the results of your pilot study, you still need to communicate your results to Dr. Thury. Talk with your group about the experiment you have conducted, what the results were, and how you interpreted those results. Then report to your instructor on what you have found.

Draft a ~250 word email to Dr. Thury containing the following information:

1. an explanation of why you are writing,
2. a description of the pilot study you have conducted, including your hypothesis and prediction, and
3. the results of the study and your interpretation of those data.

Show the typed email to your instructor. Try to be as precise and professional as possible, as Dr. Thury will be receiving dozens of emails from prospective teams and the way you write your email is as important as the actual contents.

References

- Aldo, L. 1947. On a monument to the passenger pigeon. In *Silent Wings*. Madison Society for Ornithology, May 11, 1947, 3–5.
- Clark, R.W., W.S. Brown, R. Stechert, and K.R. Zamudio. 2010. Roads, interrupted dispersal, and genetic diversity in timber rattlesnakes. *Conservation Biology* 24 (4): 1059–1069.
- Haddad, N.M., L.A. Brudvig, J. Clobert, K.F. Davies, A. Gonzalez, R.D. Holt, et al. 2007. *Crotalus horridus*. In: IUCN 2012. *IUCN Red List of Threatened Species*. Version 2012.2. <<http://www.iucnredlist.org>>. Downloaded on 16 February 2013.
- Hammerson, G.A. 2007. *Crotalus horridus*. The IUCN Red List of Threatened Species 2007: e.T64318A12765920. <<http://dx.doi.org/10.2305/IUCN.UK.2007.RLTS.T64318A12765920.en>>.



Case copyright held by the **National Center for Case Study Teaching in Science**, University at Buffalo, State University of New York. Originally published November 3, 2016. Please see our **usage guidelines**, which outline our policy concerning permissible reproduction of this work. Image in title block is a detail from Thomas Cole's "View of the Round-Top in the Catskill Mountains" (1827).