

On converting a side-pairing to a handle decomposition

Dubravko Ivanšić

Murray State University

Abstract

We give a method for obtaining a handle decomposition of an n -manifold if the manifold is given by isometric side-pairings of a polyhedron in \mathbf{E}^n , \mathbf{S}^n or \mathbf{H}^n . Every cycle of k -faces on the polyhedron corresponds to an $(n - k)$ -handle of the manifold.

Two applications of the method are given. One helps recognize when a noncompact hyperbolic 3-manifold is a complement of a link in S^3 (and automatically produces the link diagram), the other shows that a topological S^4 described by the author in [4] is diffeomorphic to the standard differentiable S^4 .

MSC: 57M50, 57M25, 57Q45

Keywords: handle decomposition, hyperbolic manifold, link complement, simply-connected closed 4-manifold

1 Introduction

Let X be any of the three constant-curvature spaces \mathbf{E}^n , \mathbf{S}^n or \mathbf{H}^n , and let G be a discrete subgroup of isometries of X . By a geometric manifold we mean a manifold of the form $M = X/G$.

Many examples of geometric manifolds are given through side-pairings of a polyhedron $P \subset X$, this being a convenient and topologically revealing way of describing a manifold. On the other hand, general manifolds are often given using a handle decomposition, which lends itself to manipulation and simplification through handle moves.

In this paper we give a method that converts a polyhedron-side-pairing representation of a manifold into a handle decomposition of the manifold. The method associates every cycle of k -faces in the polyhedron to an $(n - k)$ -handle in the handle decomposition. While the method works in any dimension, it is most interesting to us in dimensions $n = 3, 4$, where we give two applications.

In section 2 we motivate and illustrate the method by describing it in dimension 3, where it is easily understood.

Section 3 provides an application of the method to hyperbolic 3-manifolds. Many examples of finite-volume hyperbolic manifolds M are known to be complements of links in the

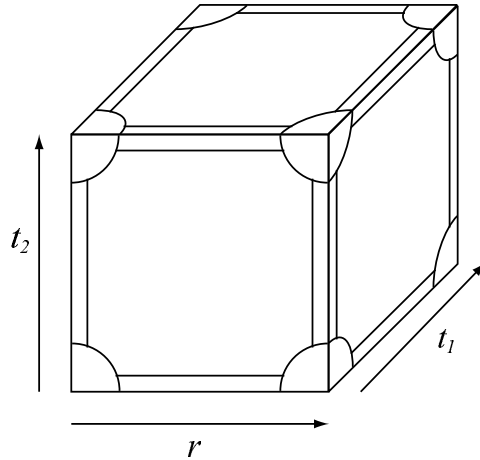

Figure 1: Cube with side-pairing, neighborhoods of faces

3-sphere. However, proving that a particular manifold is a complement of a particular link is often demanding and pushes the limits of intuition. Furthermore, proofs that the author has seen usually require that the link is known before one executes the proof. (The only procedure the author is aware of that does not require this is described in Francis' book [2], however, the procedure is significantly restricted by the type of side-pairings it works for.) We use the method of Section 2 to obtain a handle decomposition of a given hyperbolic manifold. Using handle moves one can easily show that the manifold is a complement of a link in the 3-sphere, while the handle moves produce the diagram of the link as the computation progresses. This procedure has worked in a straightforward way on all the standard examples (complements of the figure-8 knot, the Whitehead link and the Borromean rings) and some less standard ones, like those in [9].

In Section 4 we justify the conversion method for all dimensions.

Section 5 details how to get handle decomposition diagrams in dimension 4.

Section 6 gives an application of the conversion method in dimension 4. J. Ratcliffe, S. Tschantz and the author have found a dozen examples (see [4, 5]) of noncompact hyperbolic 4-manifolds that are complements of varying numbers of tori and Klein bottles in a topological 4-sphere N . We work out the handle decomposition of one N in order to show that it is diffeomorphic to the standard differentiable 4-sphere, which the original proof was not equipped to do.

As a matter of fact, the author's motivation for developing the conversion method was the problem of whether the topological 4-spheres found in [4, 5] were diffeomorphic to the standard 4-sphere. The dimension-3 application from Section 3 was found afterwards.

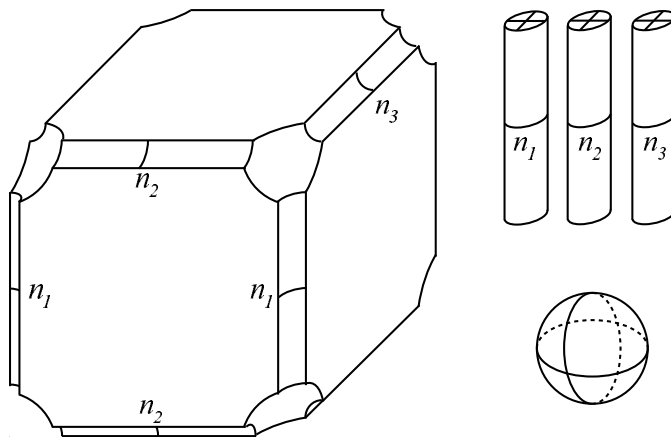

Figure 2: Handles as assemblies of face neighborhoods

2 Conversion in dimension 3

Let P be a polyhedron in $X = \mathbf{H}^3$, \mathbf{E}^3 or \mathbf{S}^3 with a side-pairing defined on it that gives a geometric manifold M . In Fig. 1 a cube is drawn as an example: its top and bottom and front and back sides are paired by a translation, while the left and right sides are paired by a translation followed by a 180° rotation around the translation vector.

Select neighborhoods (for example, ϵ -neighborhoods) around vertices and edges like in Fig. 1. The neighborhoods should match via the side pairing. Let V_1, \dots, V_m be neighborhoods of a cycle of vertices $\{v_1, \dots, v_k\}$ (a cycle of faces comprises all the faces of P that are identified by the side-pairing). Then $V_1 \cup \dots \cup V_m$ assembles into a ball V in M . In our example, all the vertices are in the same cycle, and V_i is an eighth of a ball. Eight such pieces, of course, assemble in a ball.

Removing neighborhoods of all vertices from P removes parts of the neighborhoods of the edges. Let E_1, \dots, E_n be the truncated neighborhoods of a cycle of edges e_1, \dots, e_n . Then $E_1 \cup \dots \cup E_n$ assembles into a solid cylinder around a truncated edge, which can also be viewed as a 3-ball E in M .

Let H_1 be the solid obtained by removing neighborhoods of vertices and truncated neighborhoods of edges from P . On the surface of H_1 it is the truncated sides that get identified, representing pairwise-identified disjoint disks, so H_1 projects to a handlebody H in M under the quotient map $P \rightarrow M$. The feet of the 1-handles of H are the truncated sides on H_1 (see [3] for basics of handles and handle decompositions). Now, the ball $E = D^2 \times D^1$ from above is attached to H along $\partial D^2 \times D^1$, making it a 2-handle of M . In our example, there are three cycles of edges, and the visible portions of attaching circles n_1 , n_2 and n_3 of the corresponding 2-handles are shown in Fig. 2. Of course, the ball V from above may be viewed as $V = D^3 \times D^0$, and it attaches to the 0-, 1- and 2-handles along $\partial D^3 \times D^0$, making it a 3-handle.

If P is a polyhedron in \mathbf{H}^3 with some ideal vertices, the procedure works the same way,

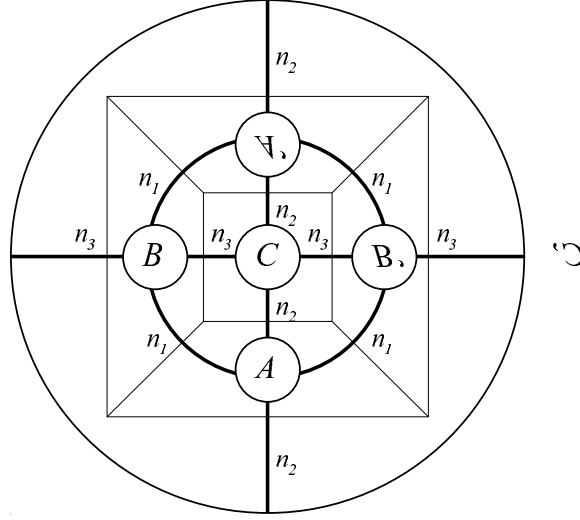

Figure 3: Handle decomposition for the side-pairing from Fig. 1

except, instead of removing a neighborhood of the vertex we remove a horoball centered at the ideal vertex.

Therefore, to get a handle decomposition diagram (pairs of disks in \mathbf{R}^2 representing feet of 1-handles, curves outside of the disks representing attaching circles of 2-handles), do the following:

- Project the surface of the polyhedron P to $\mathbf{R}^2 \cup \infty$ and draw its decomposition into sides. (If the polyhedron has ideal vertices, one may draw them as empty circles.)
- Draw a disk inside every side that represents one of the feet of a 1-handle (paired sides correspond to feet of 1-handles). One of the disks may be the outside of the diagram since a sphere (the surface of P) was projected to \mathbf{R}^2 .
- If two sides are adjacent along an edge e , draw an arc crossing e once between the disks corresponding to the sides. The union of arcs crossing edges that are in the same cycle comprise the attaching circle for a 2-handle.
- Attention needs to be paid to how disks (feet of 1-handles) are identified, as the transformation that identifies them depends on the transformation that identifies the corresponding sides of P . (We do not assume that the feet of 1-handles are identified by a reflection in the bisector of the centers, as is common in handle-decomposition diagrams.)
- It is not necessary to keep track of 3-handles, since there is only one way then attach them. Furthermore, if the polyhedron is hyperbolic and has only ideal vertices, there are no 3-handles. However, if some of the vertices are real and some ideal, it may be

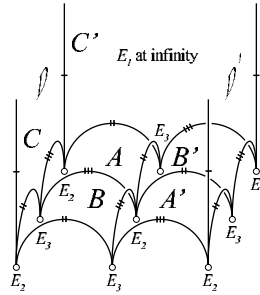

Figure 4: Wielenberg's side-pairing on a hyperbolic polyhedron

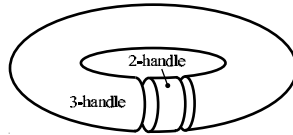

Figure 5: Attaching a solid torus along boundary is like adding a 2-handle and a 3-handle

useful to note where on the diagram the 3-handles attach. If necessary, one might put a full circle in \mathbf{R}^2 wherever there was a real vertex to indicate that the boundary of a 3-ball is attached to that section of \mathbf{R}^2 , and put an empty circle wherever there was an ideal vertex to signify that this part of \mathbf{R}^2 becomes a part of the boundary of the manifold.

Fig. 3 illustrates the process above for the cube example at the beginning of the section. The letters inside the disks suggest the map that pairs the two disks, for example, A and A' are paired by a reflection in their bisector, while B and B' are paired by a reflection in the bisector, followed by a rotation by 180° .

3 Identifying hyperbolic 3-manifolds as link complements in the 3-sphere

In this section, we apply the conversion method of § 2 to illustrate a procedure that attempts to show that a finite-volume noncompact hyperbolic manifold is the complement of a link in the 3-sphere. If the procedure is carried out successfully, it also produces the link diagram.

We will use Wielenberg's example 4 from [9]. In that paper, the following algebraic theorem of Riley's [8] is used to determine that certain hyperbolic manifolds M are complements of links $S^3 - L$: if $\pi_1 M$ is anti-isomorphic to $\pi_1(S^3 - L)$, then $M \cong S^3 - L$. In order to verify the anti-isomorphism, however, the link has to be known in advance to get the presentation of $\pi_1(S^3 - L)$. Our procedure produces the link diagram as it is carried out.

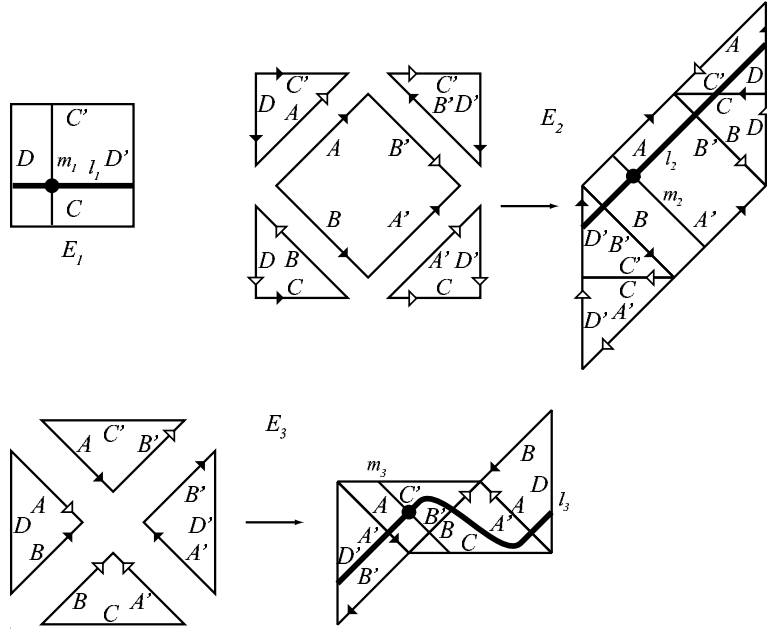

Figure 6: Finding suitable meridians in boundary components

The hyperbolic manifold comes from pairing the sides of the polyhedron P pictured in the upper half-space model in Fig. 4. The vertical sides C, C' and D, D' are paired by translations. Sides A and A' are paired by a reflection in the vertical plane passing through the point where A and A' touch. Side B is sent to B' by a reflection in the vertical plane that slices B and B' in half, followed by a translation that slides B to B' .

A finite-volume orientable noncompact hyperbolic 3-manifold M is diffeomorphic to the interior of a compact 3-manifold \overline{M} , whose boundary components are all tori. If solid tori are glued onto the boundary components and the result is a 3-sphere, then M is diffeomorphic to $S^3 - L$, where L is the collection of the center circles of the solid tori we added.

As Fig. 5 suggests, gluing a solid torus to a component T^2 of $\partial\overline{M}$ is the same as attaching a 2-handle and a 3-handle to \overline{M} . The attaching circle of the 2-handle can be any nontrivial simple closed curve on T^2 . The components of $\partial\overline{M}$ are assembled from polygons, called vertex links, that are intersections of small enough horospheres centered at ideal vertices with the polyhedron P . In our example, the vertex links are 45° - 45° - 90° triangles and squares. The three cycles of ideal vertices, E_1, E_2 and E_3 are indicated in Fig. 4, and in Fig. 6 the vertex links from each cycle are drawn together and it is shown how they assemble into parallelograms that give rise to toral boundary components of \overline{M} .

For every boundary component T^2 we now choose two curves representing generators of $\pi_1 T^2$. One will serve as the attaching circle of the 2-handle, making it a meridian of the attached solid torus. The other automatically becomes a longitude of the solid torus, thus isotopic to its center circle. In Fig. 6, the attaching circle is the thinner arc m_i and the longitude is the thicker arc l_i , $i = 1, 2, 3$.

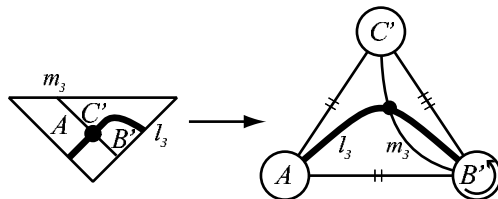

Figure 7: Converting one diagram to another

When choosing the attaching circle, choose a curve in T^2 as short as possible (in its Euclidean metric). If the length of the attaching circle is more than 2π , the 2π -theorem on hyperbolic Dehn surgery ([1]) asserts we will get a hyperbolic manifold. Thus, if $\partial\overline{M}$ has only one component, we will have failed to produce S^3 . If $\partial\overline{M}$ has several components, it is possible that some combination of long and short attaching circles still produces S^3 , but chances are probably better the greater the number of shorter ones are chosen.

Let M_W now denote the manifold resulting from the side-pairing on the polyhedron above. Since there are three cycles of ideal vertices, $\partial\overline{M}_W$ will have three components. Step 0 of Fig. 8 shows the handle decomposition of \overline{M}_W , obtained using the conversion method from §2. The feet A, A', C, C' and D, D' of 1-handles are all identified by a reflection in the perpendicular bisector of the line connecting their center. The feet B and B' are identified by a reflection in the line joining their centers, followed by a translation that moves B to B' , so that the arrows drawn inside match up. Attaching circles coming from cycles of edges are labeled I, II and III. The attaching circles that we chose in Fig. 6 are also drawn in and labeled m_1, m_2 , and m_3 . Their corresponding longitudes l_1, l_2 and l_3 , are drawn as thick curves.

Fig. 7 shows to make the easy correspondence between a triangle appearing in Fig. 6 and the section of the boundary of the handlebody in step 0 of Fig. 8 necessary to draw in the longitudes and meridians. The handle decomposition of \overline{M}_W does not have any 3-handles, since P did not have any real vertices. However, closing off $\partial\overline{M}_W$ with three solid tori adds three 3-handles.

Thus, step 0 of Fig. 8 shows the handle decomposition of a closed manifold that we hope is S^3 . In the diagrams in Figures 8 and 9 we perform handle moves in order to simplify the handle decomposition (see [3] for basics on handle moves). Keep in mind that the curves labeled l_1, l_2 and l_3 are not attaching circles, but merely curves drawn on the surface of the handlebody whose position we keep track of. In particular, attaching circles may freely be isotoped over these curves and may cross them. It is easy to see that a crossing by an attaching circle will become an undercrossing if the corresponding 2-handle cancels a 1-handle that carries one of the longitudes.

Step 0. Attaching circles m_2 and m_3 go across 1-handles AA' and CC' only once, respectively, so their corresponding 2-handles cancel the 1-handles AA' and CC' . Step 1 shows the handle decomposition after this cancellation.

Step 1. Attaching circles II and III, which loop from feet B' and B can be slid over

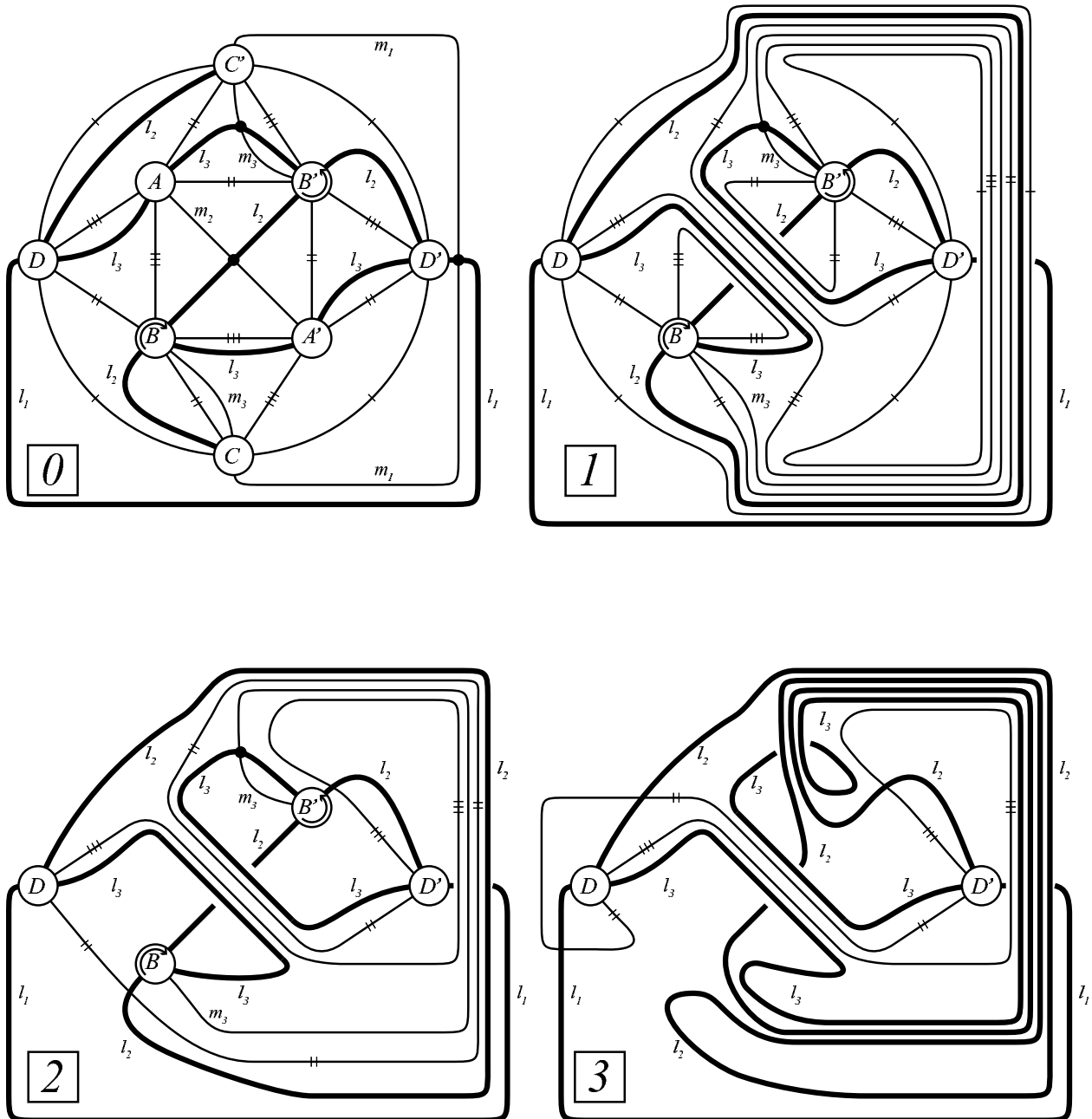

Figure 8: Handle moves, steps 0–3

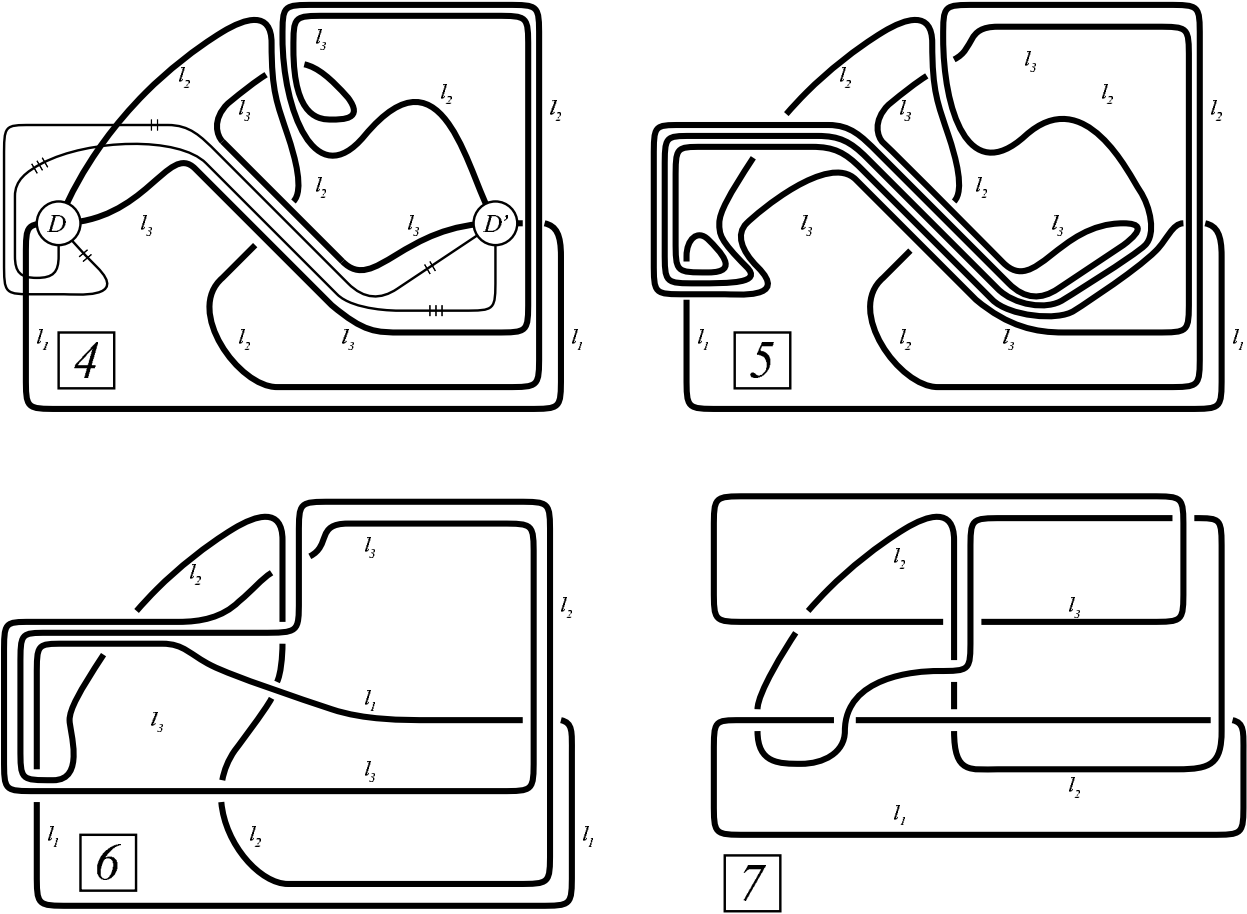

Figure 9: Handle moves, steps 4–7

the 1-handle BB' and then off feet B and B' , respectively. Moreover, the looping part of attaching circle I, at near right, may be isotoped to foot D' and then across and off handle DD' , after which I is a simple closed curve bounding a disk (on the outside) that may be pushed away from the diagram. A 2-handle whose attaching circle bounds a disk disjoint from the rest of the diagram simply encloses a 3-handle if the manifold is compact, like in our case. The 2- and 3-handles then cancel. Step 2 shows the handle decomposition after the isotopies and cancellation.

Step 2. We now notice that the vertical portion of attaching circle II can be isotoped outside of the diagram to the right and “wrapped” across ∞ to its new position shown in Step 3. Attaching circle m_3 crosses 1-handle BB' only once, causing cancellation of the 2-handle corresponding to m_3 and the 1-handle BB' .

Step 3. Before we carry out further cancellation, we simplify the picture a bit. We isotope attaching circle III around D' so it attaches at the bottom. Notice that this includes a slide of the part of III that runs across the 1-handle DD' , thus the place where III attaches to D moves as well. Also, we isotope the loop of l_2 at the bottom of the diagram toward the top, and we straighten out the kink in l_3 .

Step 4. We isotope at top middle to remove the self-crossing of l_3 . Attaching circles II and III run parallel, that is, they bound an annulus. This means a 3-handle is located between them which cancels one of the 2-handles, say III. After erasing III we note that II cancels the 1-handle DD' .

Step 5. The rest is isotopy of the link components l_i , $i = 1, 2, 3$. The loop of l_3 at center right is isotoped up and to the left, and so is the section of l_2 close to it. The kinks on the left are straightened out, as is the bottom part of l_3 and the center of l_1 .

Step 6. The bottom part of l_3 is lifted and flipped to the top, l_1 is straightened out and l_2 is isotoped a little.

Step 7. After isotoping l_2 and rotating the diagram by 180° , one gets the mirror image of Fig. 7 from Wielenberg’s paper [9].

4 Converting a side pairing to a handle decomposition in dimension n

In this section we generalize the conversion method from §2 to any dimension. Let $X = \mathbf{E}^n$, \mathbf{S}^n or \mathbf{H}^n , and let P be a finite-volume, finite-sided polyhedron in X , as defined, for example, in [6]. Assume, furthermore, that every k -face of P is diffeomorphic to either D^k or $D^k - \{\text{finitely many points on } \partial D^k\}$. The former condition is in order to disallow polyhedra such as a lens in S^3 , whose 1-face is a circle, the latter to allow hyperbolic polyhedra with ideal vertices. Let there be given a side-pairing on the sides of P , again in the sense of [6], so that the space of identified points $M = P / \sim$ is a complete manifold with a geometry based on X . If M is a noncompact hyperbolic manifold, we will be getting the handle decomposition of \overline{M} , the compact manifold with boundary whose interior is M . If M is closed, we set $\overline{M} = M$.

Theorem 4.1 *Let M be a manifold obtained through a side-pairing defined on a polyhedron P in $X = \mathbf{E}^n, \mathbf{S}^n$ or \mathbf{H}^n . Suppose that every k -face of P is diffeomorphic to either D^k or $D^k - \{\text{finitely many points on } \partial D^k\}$. Then the decomposition of P into k -faces, $0 \leq k \leq n$ induces a handle decomposition of the manifold \overline{M} , where every cycle of k -faces corresponds to an $(n - k)$ -handle.*

Proof. If P is a hyperbolic polyhedron with ideal vertices, the completeness of M implies the existence of a finite collection of disjoint open horoballs $\{B_s, s \in S\}$ that are centered at ideal vertices of P and are mapped to each other under side-pairings of P . Furthermore, each B_s can be chosen so it intersects only sides of P that are incident with the ideal vertex where B_s is centered. Set $U_{-1} = \cup_{s \in S} B_s$ if P is hyperbolic with ideal vertices, otherwise set $U_{-1} = \emptyset$.

For every $k = 0, \dots, n$, we inductively define real numbers ϵ_k and “orthogonal neighborhoods” NE^k of truncated k -faces TE^k . Let $E_s^k, s \in S_k$ be the collection of k -faces of P , $k = 0, \dots, n - 1$. (Note that there is only one n -face, namely P .) If P has real vertices, there is an ϵ so that $p : X \rightarrow M$ is injective on ϵ -balls around the real vertices. Set ϵ_0 to be the smaller of ϵ and $\frac{1}{3} \min\{d(E_s^0, E_t^0) | s \neq t, s, t \in S_0\}$, otherwise (if all vertices are ideal) set $\epsilon_0 = 1$. Let $TE_s^0 = E_s^0$, let NE_s^0 denote the closed ϵ_0 -neighborhood in X of a 0-face E_s^0 , and let $U_0 = \cup_{s \in S_0} \text{int } NE_s^0$. Clearly NE_s^0 and NE_t^0 are disjoint when $s \neq t$ and p restricted to any of those neighborhoods is a diffeomorphism.

Now assume ϵ_k, U_k, NE_s^k and TE_s^k have been defined for a $0 \leq k \leq n - 2$ and every k -face $E_s^k, s \in S_k$ of P and that the restriction of p to every NE_s^k is a diffeomorphism. Let $TE_s^{k+1} = E_s^{k+1} - \cup_{-1 \leq i \leq k} U_i, s \in S_{k+1}$. Because M is a manifold, p is injective on the interior of every face. Due to compactness of every $TE_s^{k+1} \subset \text{int } E_s^{k+1}$, we can find an ϵ so that p is a diffeomorphism on an ϵ -neighborhood of TE_s^{k+1} for every $s \in S_{k+1}$. Set ϵ_{k+1} to be the smallest of $\epsilon, \frac{1}{2}\epsilon_k$ and $\frac{1}{3} \min\{d(TE_s^{k+1}, TE_t^{k+1}) | s \neq t, s, t \in S_{k+1}\}$, and let NE_s^{k+1} be the closed ϵ_{k+1} -neighborhood of TE_s^{k+1} in X with $\cup_{i=-1}^k U_i$ excluded. Let $U_{k+1} = \cup_{s \in S_{k+1}} \text{int } NE_s^{k+1}$. If $k = n - 1$, let $TE^n = P - \cup_{i=-1}^{n-1} U_i$ and $NE^n = TE^n$.

From the assumption that every E_s^k is diffeomorphic to D^k or $D^k - \{\text{finite set}\}$, it follows that TE_s^k is diffeomorphic to D^k for every $s \in S_k$. The set NE_s^k is then diffeomorphic to $D^k \times D^{n-k}$, where $TE_s^k = D^k \times 0$. Note that $x \times D^{n-k}$ is essentially in the orthogonal direction to E_s^k , except close to ∂TE_s^k , where some bending has to occur to accommodate NE_t^i , where E_t^i is a face of E_s^k . Furthermore, for every face E_t^i of $E_s^k, i \leq k$, note that NE_t^i intersects $NE_s^k = D^k \times D^{n-k}$ only along $\partial D^k \times D^{n-k}$. If P has ideal vertices, $\partial \overline{M}$ is assembled from links of ideal vertices $\partial B_s \cap P$. Clearly $\partial B_s \cap P \subset \partial D^k \times D^{n-k}$. Thus, any element of $p(\text{int } D^k \times \partial D^{n-k})$ is in $\text{int } \overline{M}$ and therefore must be in some other $p(NE_u^j)$. Our observation above then shows that $j > k$.

Let us treat $p(NE^n)$ as a 0-handle in \overline{M} . Consider an $NE_s^k, s \in S_k, k \leq n$. By our construction, p restricts to a bijection on NE_s^k , hence $p(NE_s^k)$ is an n -ball inside of \overline{M} . This gives a decomposition of \overline{M} into a collection of n -balls with disjoint interiors. If E_s^k and E_t^k are in the same cycle, then $p(NE_s^k) = p(NE_t^k)$, hence every n -ball corresponds to a cycle of k -faces for some $k \leq n$.

Define $M_k = \cup_{n-k \leq i \leq n} \cup_{s \in S_i} p(NE_s^i)$, meant to be the union of i -handles, $0 \leq i \leq k$. As above, $NE_s^k = D^k \times D^{n-k}$ and $p(\text{int } D^k \times D^{n-k})$ is contained in $\cup_{k < i} \cup_{t \in S_i} p(NE_t^i) = M_{n-k-1}$. Since M_{n-k-1} is closed, $p(D^k \times \partial D^{n-k}) \subset M_{n-k-1}$. Therefore, $p(NE_s^k)$ attaches as an $(n-k)$ -handle to M_{n-k-1} , giving us a handle decomposition of \overline{M} . \square

In the above handle decomposition of \overline{M} , we note that the attaching sphere $0 \times \partial D^{n-k}$ of the $n-k$ -handle NE_s^k is the boundary of a neighborhood in X of a point $x \in E_s^k$. Naturally, this being a neighborhood in X means that a part of it is outside of P and it intersects several translates gP of P . But then $g^{-1}((0 \times \partial D^{n-k}) \cap gP)$ is visible in P .

5 Drawing handle decomposition diagrams in dimension 4

In this section we apply the conversion method described in the previous section to dimension 4. Notation is like in the previous section and, as an illustrative example, we use as P the 4-cube whose sides are paired by translations, yielding $M = 4$ -torus.

We want to draw in $\partial D^4 = S^3 = \mathbf{R}^3 \cup \infty$ attaching spheres of the k -handle $D^{4-k} \times D^k$. The 0-handle is NE^4 , P without neighborhoods of all the k -faces. Clearly $\partial NE^4 = S^3 = \partial P$, realized by a diffeomorphism $h : \partial NE^4 \rightarrow \partial P$, a restriction of a diffeomorphism $h : NE^4 \rightarrow P$, which may be imagined as a radial projection from a point in the interior of P . Under h , $(\partial NE_s^{4-k}) \cap P$ is sent to $TE_s^{4-k} \times B^{k-1}$, a TE_s^{4-k} “thickened-up” in ∂P . Note that the thickening of TE_s^3 in ∂P is still TE_s^3 . Now, a piece of the attaching sphere $P \cap (0 \times \partial D^k)$ is sent under h to $x \times B^{k-1}$, where $x \in TE_s^{4-k}$.

Let the subdivision of ∂P into k -faces ($k \leq 3$) be drawn in $\mathbf{R}^3 \cup \infty$. As an example, take the standard “cube-within-a-cube” picture of the boundary of the 4-cube. A piece of the attaching sphere for a 1-handle $p(NE_s^3)$ is $P \cap (0 \times \partial D^1)$ which is sent to a point in TE_s^3 , chosen, for example, in its interior. The two points in the attaching sphere of a 1-handle are in paired 3-faces. The attaching region $D^3 \times \partial D^1$ is the union of paired truncated 3-faces TE_s^3 and TE_t^3 : schematically, we draw 3-balls inside TE_s^3 and TE_t^3 .

The piece inside of P of an attaching circle for a 2-handle $p(NE_s^2)$ is $P \cap (0 \times \partial D^2)$, an arc that crosses the 2-face corresponding to the 2-handle and joins the 3-faces whose intersection is the 2-face. Under h , this arc maps to the segment $x \times B^1$, $x \in TE_s^2$, visible on the left of Fig. 10.

The attaching sphere for a 3-handle is a 2-sphere, whose intersection $P \cap (0 \times \partial D^3)$ with P is a 2-ball. Under h , the 2-ball maps to the 2-ball $z \times B^2$, $z \in TE_s^1$, shown in Fig. 10.

When M is closed, it is only important how the 1- and 2-handles attach (see [3]), so the attaching spheres of 3- and 4-handles do not matter. However, it is useful to have in one’s mind pieces of the attaching spheres of the 3-handles, as they help with the framing of the attaching map of the 2-handles.

In order to specify, up to isotopy, the attaching map $\phi : D^2 \times \partial D^2 \rightarrow \partial Y$ of a 2-handle $D^2 \times D^2$, it is enough to specify the images of two parallel circles $\phi(x \times \partial D^2)$ and $\phi(y \times \partial D^2)$. As we can see on the left side of Fig. 10, if E_t^1 is incident with E_s^2 , then the intersection of

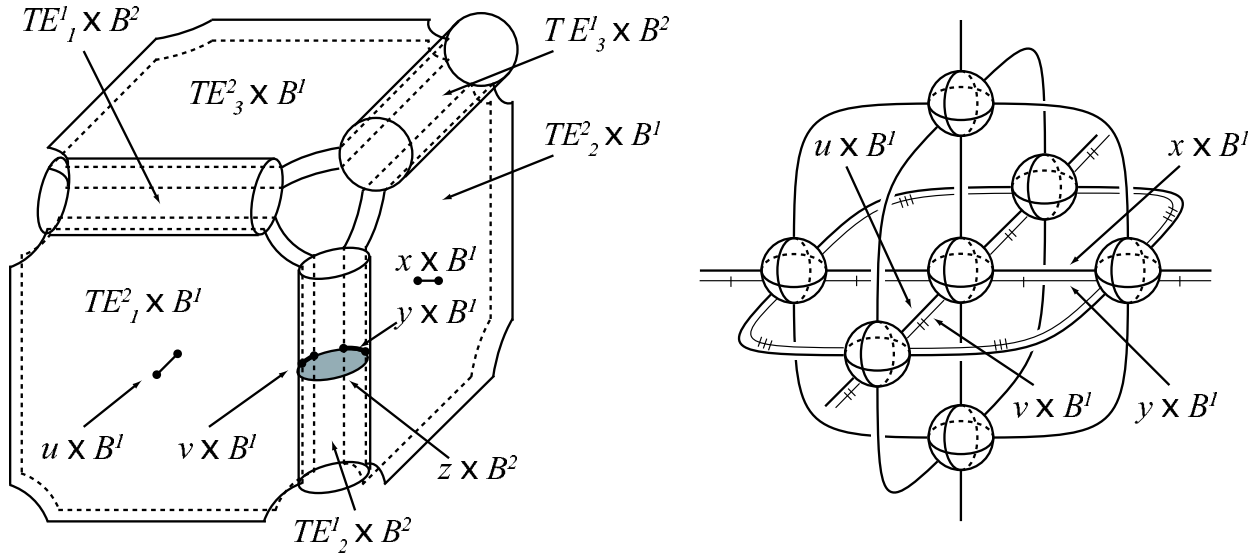

Figure 10: Arriving at a handle decomposition for the 4-torus

$z \times B^2$, $z \in TE_t^1$, with $TE_s^2 \times B^1$ is an arc $y \times B^1$, $y \in TE_s^2$. We can then choose $y \times \partial D^2$ to be the circle parallel to $x \times \partial D^2$, chosen before. (In Fig. 10, $u \times B^1$ and $v \times B^1$ are pieces of another such pair of parallel circles.)

Schematically, the portion $z \times B^2$ of the attaching sphere of the 3-handle $p(NE_t^1)$ is represented as a triangle transverse to E_t^1 , bounded by the portions $x_i \times B^1$ of attaching circles of the three 2-handles that correspond to the three 2-faces, the pairwise intersections of the three 3-faces whose intersection is the 1-face E_t^1 . One can speak of a “cycle” of triangles, the collection of triangles corresponding to 1-faces that are all in one cycle. Clearly, a cycle of triangles represents all the pieces of the attaching sphere of the 3-handle corresponding to the cycle of 1-faces.

Thus, pieces of a parallel circle may be chosen to lie in one of the triangles. Since a 2-face is incident with several 1-faces, pieces of the attaching circle of a 2-handle will be in the boundary of several triangles. We choose one to contain a piece of the parallel circle; once this is done, the remaining pieces of the parallel circle must be chosen in triangles that are in the same cycle as the one we have chosen.

We summarize how to get a picture of a handle decomposition of a 4-manifold that is the result of pairing sides of a polyhedron P .

- Draw in \mathbf{R}^3 the decomposition of $\partial P = \mathbf{R}^3 \cup \infty$ into k -faces . Inside every 3-face, draw a 3-ball. Feet of a 1-handle are the two balls inside paired 3-faces.
- We do not assume that the feet of 1-handles are identified by a reflection in the bisector of the centers, as is common. Rather, the identifying map is determined by the map that pairs the corresponding 3-faces.

- If two 3-faces are adjacent along a 2-face E^2 , draw an arc between the balls inside the 3-faces that crosses E^2 exactly once. The arcs that cross 2-faces that are in the same cycle comprise the attaching circle for a 2-handle.
- Whenever three 3-faces intersect in a 1-face we see a “triangle” whose “vertices” and edges are the already drawn 3-balls and arcs, respectively. We fill in this triangle (usually only mentally) with a surface that is transverse to the 1-face. Parallel attaching circles can be chosen to lie in these surfaces.
- Once we choose a triangle to contain a piece of the attaching circle, the remaining pieces must be chosen in triangles that are in the same cycle of triangles.

The procedure above yields the familiar handle-decomposition diagram for T^4 from the right side of Fig. 10. (see also [3], Fig. 4.42). Parallel attaching circles for three 2-handles are the arcs marked I, II and III.

6 A hyperbolic manifold as a complement of 5 tori in the standard differentiable S^4

In [4], the author showed that the double cover of M_{1011} , example no. 1011 from Ratcliffe and Tschantz’s [7] collection of noncompact finite-volume hyperbolic 4-manifolds, is a complement of 5 tori in the topological 4-sphere. The proof used Freedman’s theory, which only provides a homeomorphism to the 4-sphere. In this section we prove that the 4-sphere N from [4] is, in fact, diffeomorphic to the standard differentiable 4-sphere. We use the method of this paper to obtain a handle decomposition of the manifold N and then handle moves to simplify the decomposition down to the decomposition of the standard differentiable 4-sphere.

The 24-sided polyhedron Q that gives rise to the Ratcliffe and Tschantz’s manifolds is described in their paper [7] and in [4] and [5], where more details on its combinatorial structure can be found. Here we just recall that its sides (in the ball model of \mathbf{H}^4) are spheres of radius 1 centered at points whose two coordinates are ± 1 and the other two are zeroes. We label the spheres and the sides by S_{****} , like in [5]. For example, S_{0+0-} is the sphere centered at $(0, 1, 0, -1)$.

Each octahedral 3-face of Q has eight 2-faces, so drawing a decomposition of ∂Q would be quite involved. We will therefore jump to the handle-decomposition picture right away, by finding attaching spheres of the 1-, 2- and 3-handles on ∂Q , and projecting them to S^3 radially from the origin of B^4 . S^3 is then sent to $\mathbf{R}^3 \cup \infty$ via the Möbius transformation $g : (\mathbf{R}^4 \cup \infty) \rightarrow (\mathbf{R}^4 \cup \infty)$ that provides the standard isometry between the ball and upper-half-space models of hyperbolic space. This map is the composite of the reflection in the sphere with center $(0, 0, 0, 1)$ of radius $\sqrt{2}$, followed by a reflection in the hyperplane $x_4 = 0$. Its restriction to S^3 is given by $x \mapsto e_4 + \frac{2}{|x - e_4|^2}(x - e_4)$. (This is actually the formula for

just the first reflection, since the reflection in $x_4 = 0$ has no effect on $\mathbf{R}^3 \cup \infty$, the image of S^3 .) Note that g leaves $S^2 \subset \mathbf{R}^3 \times 0$ fixed.

As attaching spheres of 1-handles we choose points on the sides of Q closest to the origin. “Shortest” arcs connecting those points along the sides are chosen to be the pieces of attaching circles of 2-handles. Pieces of attaching spheres of 3-handles are the piecewise-spherical “triangles” bounded by the arcs, stretched across the sides.

More precisely, let r be the position-vector of a sphere S that determines a side of Q . The intersection of S and the line spanned by r is a point c in S . Let c' be the intersection of S' and the line spanned by r' , where S' is the pair of S under the side-pairing on Q . Then we choose c and c' to be the points of the attaching sphere of the 1-handle corresponding to the paired sides S and S' . If S_1 and S_2 are intersecting sides, let e be the arc that is the intersection of ∂Q and the (linear) angle spanned by position vectors r_1 and r_2 . This arc is a portion of the attaching circle of the 2-handle corresponding to the 2-face $S_1 \cap S_2$. Finally, if a side S_3 intersects S_1 and S_2 , consider the intersection f of ∂Q with the “positive cone” spanned by r_1 , r_2 and r_3 . This “triangle” is a portion of the attaching sphere of the 3-handle corresponding to the 1-face $S_1 \cap S_2 \cap S_3$. It is not clear that the overall arrangement of the spheres is such that c , c' , e and f are actually on ∂Q . (For example, c may be inside some other sphere S_0 , which would put it outside of Q .) Next, we justify that these choices are indeed on ∂Q .

Consider the sides S_{++00} , S_{+0+0} and S_{0++0} . The three sides intersect pairwise and the intersection of all three of them is a 1-face E_s^1 . Let L be the (linear) hyperplane spanned by r_{++00} , r_{+0+0} and r_{0++0} , this is the hyperplane $x_4 = 0$. It is clear that the only spheres that intersect L in more than one point are those with a 0 in the fourth position of its label. All other spheres intersect L in exactly one point, which is one of $\pm e_i$, $i = 1, \dots, 4$, that is, an ideal vertex of Q . Now, the intersection of the 12 sides S_{***0} with L is a 3-dimensional version of Q which was described and pictured in [7], Figure 5. From this picture we see that attaching spheres chosen in the way described above are on ∂Q .

A general 1-face is an intersection of 3 sides if their labels pairwise share exactly one position with the same symbol. This position could be different for each pair of sides, like in the example above, or it could be the same for all three pairs, like for the sides S_{++00} , S_{+0+0} and S_{+00+} . It is clear that any 1-face can be moved by a linear isometry of Q to one of these two prototypical 1-faces (permute the coordinates and reflect in coordinate hyperplanes). Furthermore, there is a linear isometry of Q that sends S_{++00} , S_{+0+0} and S_{0++0} to S_{++00} , S_{+00+} and S_{+0+0} , respectively; its matrix is

$$\frac{1}{2} \begin{bmatrix} 1 & 1 & 1 & -1 \\ 1 & 1 & -1 & 1 \\ -1 & 1 & 1 & 1 \\ 1 & -1 & 1 & 1 \end{bmatrix}.$$

This shows that the situation illustrated by the sides S_{++00} , S_{+0+0} and S_{0++0} is generic, so all choices for attaching spheres done in the way described above are valid.

We now have to see where the attaching spheres are sent under the composite gp , where

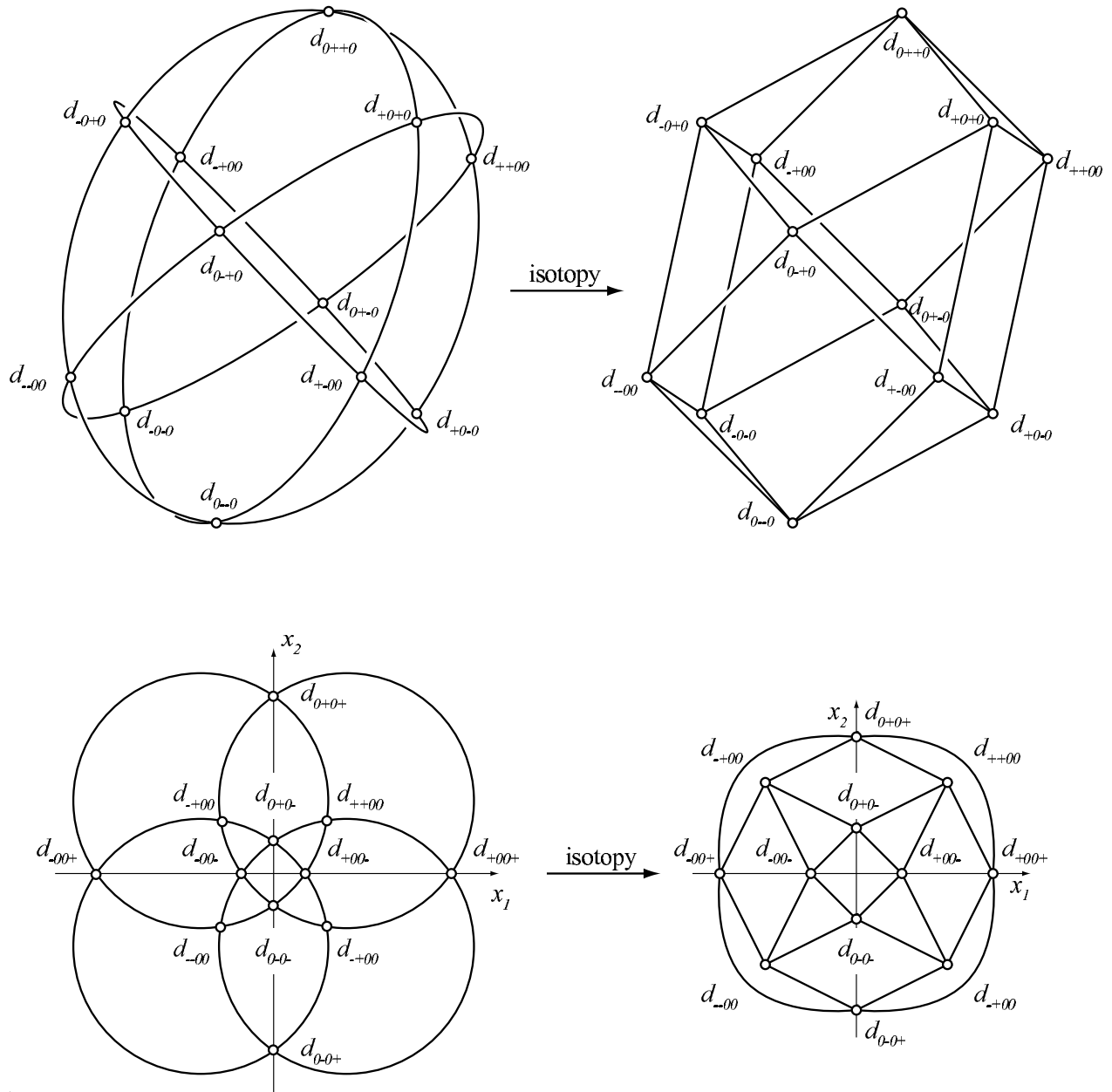

Figure 11: Finding attaching spheres for M_{1011}

$p : \partial Q \rightarrow S^3$ is the radial projection. The intersection of each position vector r_{****} with S^3 is $\frac{1}{\sqrt{2}}r_{****}$. The points of form $\frac{1}{\sqrt{2}}r_{***0}$ are on $S^2 \subset S^3$, which is fixed by g . Furthermore, an easy computation shows that $g(\frac{1}{\sqrt{2}}r_{***+}) = (\sqrt{2}+1)(*, *, *, 0)$ and $g(\frac{1}{\sqrt{2}}r_{***-}) = (\sqrt{2}-1)(*, *, *, 0)$.

As above, let c_i be the point of intersection of a sphere (side) S_i with the line spanned by the position vector r_i of the center of S_i , $i = 1, 2, 3$. If sides S_1 and S_2 intersect, consider the intersection C of S^3 and the linear plane spanned by r_1 and r_2 (part of C is the radial projection of a piece of the attaching circle). This is a circle, so $g(C)$ is a circle, since g is a Möbius transformation. Since C also contains $-r_1$ and $-r_2$, the circle $g(C)$ will contain the four points $gp(\pm c_1)$ and $gp(\pm c_2)$. Once we have the four points drawn, the circle $g(C) \subset \mathbf{R}^3$ will be easy identify. The arc of the circle between $gp(c_1)$ and $gp(c_2)$ is a part of the attaching circle for the 2-handle corresponding to the 2-face $S_1 \cap S_2$. Now, if sides S_1 , S_2 and S_3 all intersect in a 1-face E^1 , part of the attaching sphere corresponding to E^1 is the “triangle” f that is the intersection of the positive cone generated by r_1 , r_2 and r_3 with ∂Q . Radial projection to S^3 followed by g maps the triangle to a spherical triangle bounded by arcs of circles $g(C)$ that were just described.

The top left of Fig. 11 shows the points $d_{****} = gp(c_{****})$ and the circles $g(C)$ for the sides S_{**00} , S_{*0*0} and S_{0**0} . The bottom left of Fig. 11 does the same for the sides S_{**00} , S_{0*0*} and S_{*00*} . The complete picture for Q is obtained by rotating the bottom left by $\pi/2$ around the x_1 -axis, then around the x_3 -axis, and taking the union of the resulting three figures with the top left of Fig. 11. To make drawing of pictures easier, we isotope the positions of $gp(c)$'s a little and replace curved arcs $g(C)$ mostly by straight lines, as seen on the right side of Fig. 11.

We note that pieces of the attaching circles all lie in one of the coordinate planes or on S^2 . (In the straight-edge version of the diagram we imagine this S^2 as the surface consisting of 6 rectangles and 8 triangles, spanned by the points $g(c)$). We assume, as discussed in §5, that pieces parallel circles always lie in the triangles in the diagram. Note that each triangle can be taken to lie in one of the coordinate planes or on S^2 .

The handle decomposition of \overline{M}_{1011} is the right half of Fig. 12, where the outside- and inside-most attaching circles are not shown to maintain clarity of picture. If every triangle in the picture is filled in, we note that it will consist of eight “octahedra”, each of which corresponds to the link of the ideal vertices v_{*000} , v_{0*00} , v_{00*0} and v_{000*} , which is a cube (three pairs of opposing sides/feet of 1-handles). To better see the octahedra, we have separated them on Fig. 13. Note that six are shown; the two missing ones, corresponding to v_{000+} and v_{000-} , are the same ones that are missing from Fig. 12. As a matter of fact, the space between the described octahedra forms sixteen more octahedra, corresponding to the ideal vertices of form v_{****} (see one in Fig. 15).

A side-pairing $f : S \rightarrow S'$ of any of Ratcliffe and Tschantz's examples is always of the form ru , where u is a composite of reflections in the coordinate planes, and r is a reflection in S' . The restriction of f to ∂Q is all that matters to us, so u explains how feet of 1-handles are identified. Note that conjugating by g the reflections in hyperplanes $x_1 = 0$, $x_2 = 0$ and $x_3 = 0$ gives the same reflections, while conjugating the reflection in $x_4 = 0$ gives the reflection in the unit sphere. Using the convention from [5] we name the side-pairings for

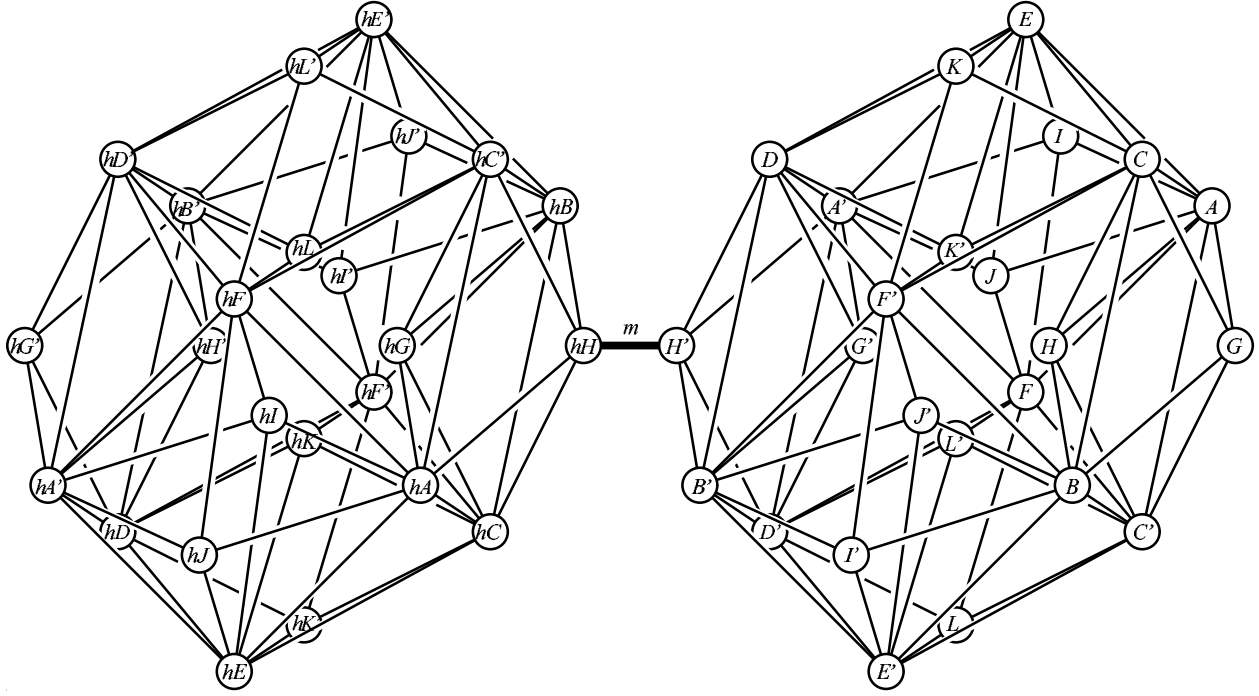
Figure 12: Handle decomposition of \tilde{M}_{1011}

M_{1011} by letters a, b, \dots, k, l as follows. (The composite of reflections that pair the sides is under the arrow.)

$$\begin{array}{llll}
 S_{+++0} \xrightarrow[\text{---+++}]{a} S_{-+00} & S_{+-00} \xrightarrow[\text{---+++}]{b} S_{--00} & S_{+0+0} \xrightarrow[\text{+++--}]{c} S_{+0-0} & S_{-0+0} \xrightarrow[\text{+++}]{d} S_{-0-0} \\
 S_{0+++} \xrightarrow[\text{-----}]{e} S_{0--0} & S_{0+-0} \xrightarrow[\text{-----}]{f} S_{0-+0} & S_{+00+} \xrightarrow[\text{-----}]{g} S_{-00-} & S_{+00-} \xrightarrow[\text{-----}]{h} S_{-00+} \\
 S_{0+0+} \xrightarrow[\text{+---+}]{i} S_{0-0+} & S_{0+0-} \xrightarrow[\text{+---+}]{j} S_{0-0-} & S_{00++} \xrightarrow[\text{++++-}]{k} S_{00+-} & S_{00-+} \xrightarrow[\text{++++-}]{l} S_{00--}
 \end{array}$$

Furthermore, for simplicity of notation, if a letter s pairs two sides, we relabel the originating side with S and $s(S)$ by S' . Thus, $d = \text{reflection in plane } x_3 = 0$ sends side $D = S_{-0+0}$ to side $D' = S_{-0-0}$.

Let $G_{1011} \subset \text{Isom}(\mathbf{H}^4)$ be the fundamental group of M_{1011} and let H_{1011} be the subgroup of orientation-preserving isometries in G_{1011} .

Of course, G_{1011} is generated by a, b, \dots, l . We are really interested in the orientable double cover \tilde{M}_{1011} of M_{1011} , whose fundamental polyhedron consists of two copies of Q with suitably paired sides. It is easy to see (and is explained in §3 of [4]) that the fundamental polyhedron for H_{1011} is $Q \cup hQ$, where h is one of the above listed generators of G , that is also, being orientation reversing, a coset representative for the nontrivial right coset of H_{1011} in G_{1011} . The discussion in [4] also shows that sides of $Q \cup hQ$ are paired according to the following rule. Let S, S' be sides of P paired by the transformation $s \in G$. If s is orientation-reversing, then side S is paired to hS' via hs and side hS is paired to S' via sh^{-1} . If s is orientation-preserving, then S is paired to S' via s and hS is paired to hS' via hsh^{-1} .

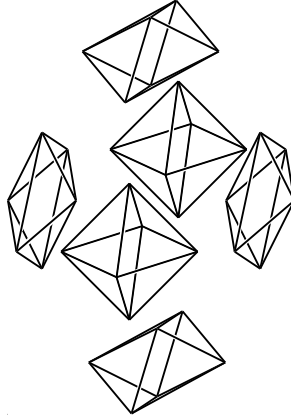

Figure 13: Octahedra appearing in Fig. 12, separated

We may view the handle decomposition of \tilde{M}_{1011} as having two 0-handles (corresponding to Q and hQ) and a 1-handle joining them (coming from the paired sides H' and hH). Since Q and hQ lie on opposite sides of the hyperplane H' , it is clear that the handle decomposition of \tilde{M}_{1011} can be drawn by drawing two handle-decompositions of \bar{M}_{1011} side-by-side while identifying H' and hH . The same effect is achieved by drawing them side-by-side and introducing a 2-handle canceling the 1-handle coming from pairing H' to hH .

The handle decomposition for \tilde{M}_{1011} is the entire diagram in Fig. 12. The part coming from Q we take to be centered at 0, the part coming from hQ we center at $(-6, 0, 0)$, the two portions being symmetric in the plane $x_1 = -3$. To get proper labeling on the feet of 1-handles of the hQ -part, we recall that they are the result of applying $h = ru_{---}$ to Q , thus we need to reflect the picture on the right in planes $x_1 = 0, x_2 = 0, x_3 = 0$ and the unit sphere centered at 0, and then apply the reflection r in the plane $x_1 = -3$.

Putting together all the facts from above, the feet of the 1-handles in the decomposition in Fig. 12 have the following identification pattern:

$$\begin{aligned}
 & A, B, C, D, I, J, K, L, hA, hB, hC, hD, hI, hJ, hK, hL \mapsto \\
 & A', B', C', D', I', J', K', L', hA', hB', hC', hD', hI', hJ', hK', hL' \\
 & \qquad \qquad \qquad \text{via reflection in the bisector of the feet} \\
 & E, F, G, H, E', F', G', H' \mapsto hE', hF', hG', hH', hE, hF, hG, hH \\
 & \qquad \qquad \qquad \text{via reflection in } x_1 = -3.
 \end{aligned}$$

The manifold \tilde{M}_{1011} has 5 three-torus boundary components, each of those an S^1 -fiber bundle over T^2 . Closing off the boundary components involves filling in each fiber with a disc, resulting in a closed manifold N . Equivalently, this can be achieved by attaching a $T^2 \times D^2$ to each component of $\partial\tilde{M}_{1011}$. A handle decomposition for $T^2 \times D^2$ derived from the simplest handle decomposition for T^2 has one 0-handle, two 1-handles and one 2-handle. Attaching it to \tilde{M}_{1011} results in adding one 2-handle, two 3-handles and one 4-handle to the decomposition,

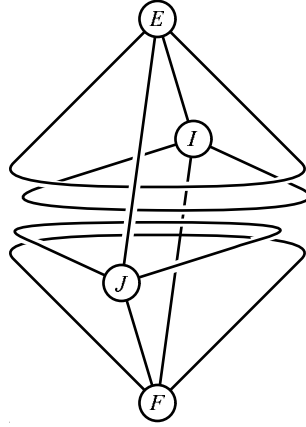

Figure 14: Octahedron corresponding to v_{0+00} after AA' is canceled by a 2-handle.

since the handles in the decomposition of $T^2 \times D^2$ must be viewed in an upside-down way (see [3]), as it is attached to \tilde{M}_{1011} . The attaching circle of the 2-handle is any fiber in the bundle. As selected and illustrated in [4], in four of the boundary components, the fibers are represented by a straight-line segment joining opposing sides of the cube that is the vertex link, therefore, the attaching circle of the 2-handle is a line-segment joining two opposed feet of 1-handles in the octahedron that corresponds to the vertex link. Since the parallel circle is another fiber, we may assume it is simply a parallel line-segment.

We now simplify the handle decomposition of N using handle moves. We repeatedly make use of the following proposition:

Proposition 6.1 ([3], modified Proposition 5.1.9) *If the handle decomposition of a closed manifold contains an attaching circle of a 2-handle that can be isotoped so that it bounds a disc disjoint from the rest of the diagram, and the disc contains its parallel circle, then the 2-handle cancels a 3-handle from the decomposition (and we may erase the 2-handle from the diagram).*

In order to better see what goes on in the complicated diagram we consider sections with the coordinate planes x_1x_2 , x_1x_3 , x_2x_3 and its parallel plane $x_1 = -6$ (“ x_2x_3 -planes”), and the two spheres S^2 , displayed in this order in Figures 16–22. Since pieces of the parallel circles are on one of those surfaces, if isotopy of the diagram stays parallel to the surface, those pieces remain in the surface, so are easy to track. On occasion, pieces of parallel circles are not on the default surfaces — it is either obvious where they are, or it is noted.

Handle moves are tracked in Figures 16–22 by drawing what happens in the sections with the mentioned planes. The topmost box of the explanation describes which 1- and 2-handles have canceled. The middle four boxes describe subsequent isotopies, each of the four pertaining to the part of the diagram in the same relative position as the box. The bottom box describes cancellation of 2- and 3-handles owing to Proposition 6.1. Note that 1-handles are designated by labels on the corresponding paired sides.

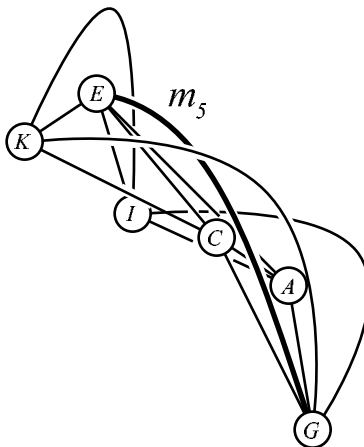

Figure 15: Position of m_5 in octahedron corresponding to v_{++++}

One could wonder if isotopy or handle cancellation in one of the planes interferes with the situation in the other. A little 3-dimensional insight helps one see that there is no problem. A picture such as Fig. 14, which is typical, may help the reader see what happens after a 1-handle cancels with a 2-handle. This picture shows the octahedron corresponding to v_{0+00} after 1-handle AA' was canceled by a 2-handle.

The initial handle decomposition also includes thirty-four 3-handles and five 4-handles. Twenty-four of the 3-handles come from cycles of 1-faces, the remaining ten 3-handles and five 4-handles come from handle decompositions of attached $T^2 \times D^2$'s. As explained in [3], §4.4, because N is a closed manifold, 3- and 4-handles can attach essentially in only one way, so there is no need to keep track of them.

After Fig. 22, the 3-dimensional diagram is simple enough that we can draw it on one picture. In steps thus far, we have not pictured the additional 2-handle coming from closing off the fifth boundary component. The choice $e^{-1}g$, made in [4], is represented by a union of line-segments: one joining the opposite sides S_{+00+} and S_{0++0} of the cube that is the vertex link at v_{++++} , and one joining the opposite sides S_{0--0} and S_{-00-} of the cube that is the vertex link at v_{----} . This corresponds to two segments joining E and G and hE' and hG' in our diagram. Fig. 15 shows the first one in the “octahedron” corresponding to v_{++++} : we can see that all the moves done so far on the diagram do not affect it (in particular, it lies outside of the two S^2 's), so it can be drawn in the same position in the overall picture.

After the final 2-handles and 3-handles cancel in step 12 of Fig. 23, we arrive at an empty diagram (one 0-handle and some 3- and 4-handles). Since this is the handle decomposition of the standard differentiable 4-sphere, we conclude that N is diffeomorphic to it.

Incidentally, by keeping track of the 3- and 4-handles throughout the computation we see that the final handle decomposition has four 3-handles and five 4-handles. However, since the boundary of their union is S^3 , the union must be D^4 (otherwise the boundary would be a connected sum of $S^1 \times S^2$'s).

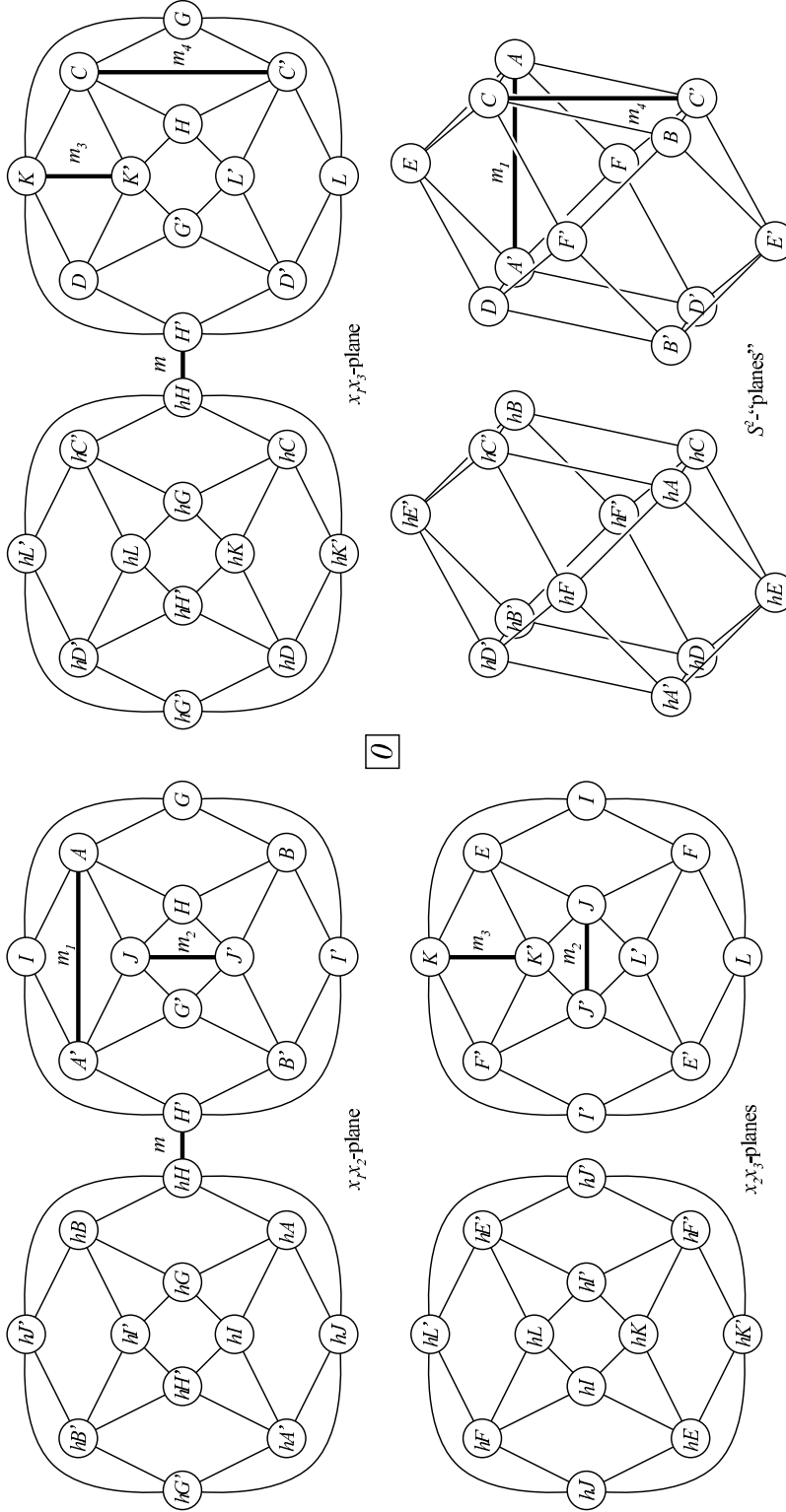

Figure 16: Step 0, initial handle decomposition

This is the initial setup. Altogether, there are twenty-four 1-handles, fifty-four 2-handles, and also thirty-four 3-handles and five 4-handles, whose attaching spheres we do not need to keep track of.

Each of the 2-handles m_1 , m_2 , m_3 and m_4 (coming from attaching $T_2 \times D^2$ to M_{1011}) passes exactly once over 1-handles AA' , JJ' , KK' and CC'' , respectively, so those 2-handles cancel the 1-handles.

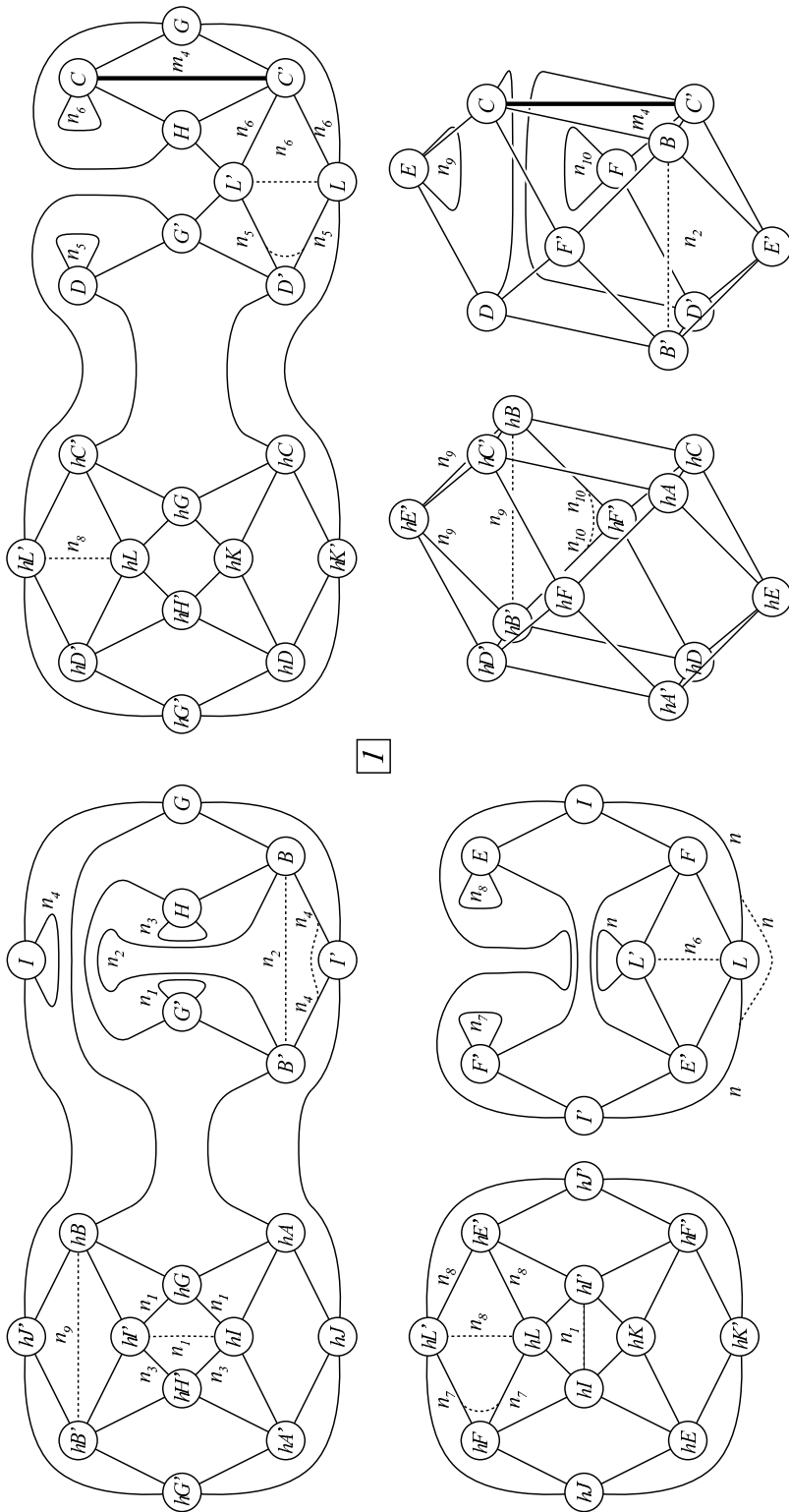

Figure 17: Step 1

2-handles m , m_1 , m_2 and m_3 cancel $H'hH$, AA' , JJ' and KK' , respectively	n_6 slides over CC' and off foot C' into dotted position
n_1 slides over the 1-handle hGG' and off the foot hG into position indicated by the dotted line	n_5 slides over DD' and off foot D' into dotted position
n_2 isotopes into dotted position	n_9 slides over EhE' and off foot hE' into dotted position
n_4 slides over I' , and off foot I' into dotted position	n_{10} slides over FhF' and off foot hF' into dotted position
n_7 slides over $F'hF'$ and off foot hF' into dotted position	
n_8 slides over EhE' and off foot hE' into dotted position	
n slides over LL' and off foot L' into dotted position	

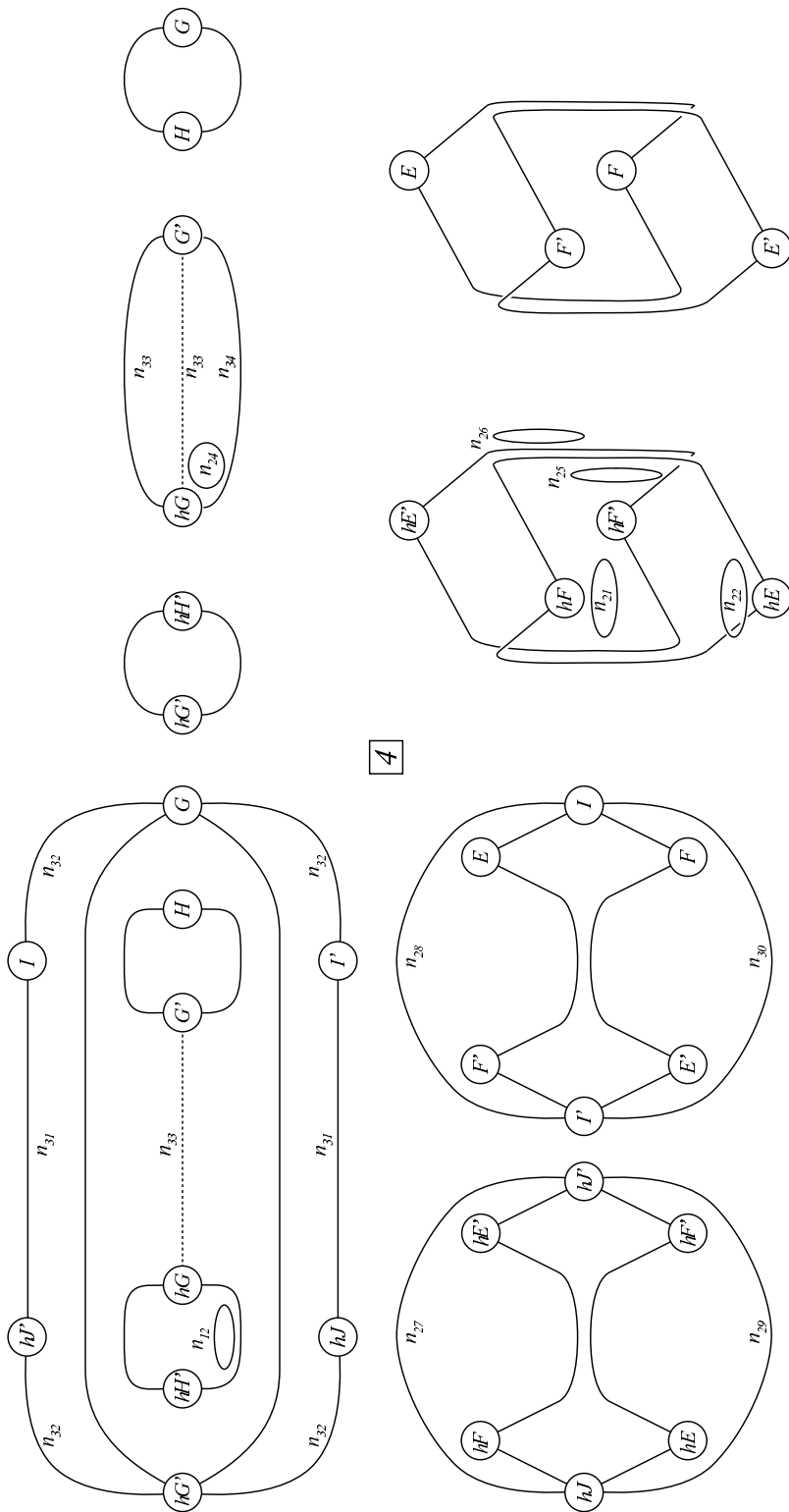

Figure 20: Step 4

n_{11}, n_{18} cancel $hAhA'$, $hChC'$ respectively	isotopy simplifies picture
	n_{33} isotopes to dotted position
	n_{25} isotopes
	n_{26} isotopes
$n_{12}, n_{24}, n_{21}, n_{22}, n_{25}, n_{26}$ cancel a 3-handle	

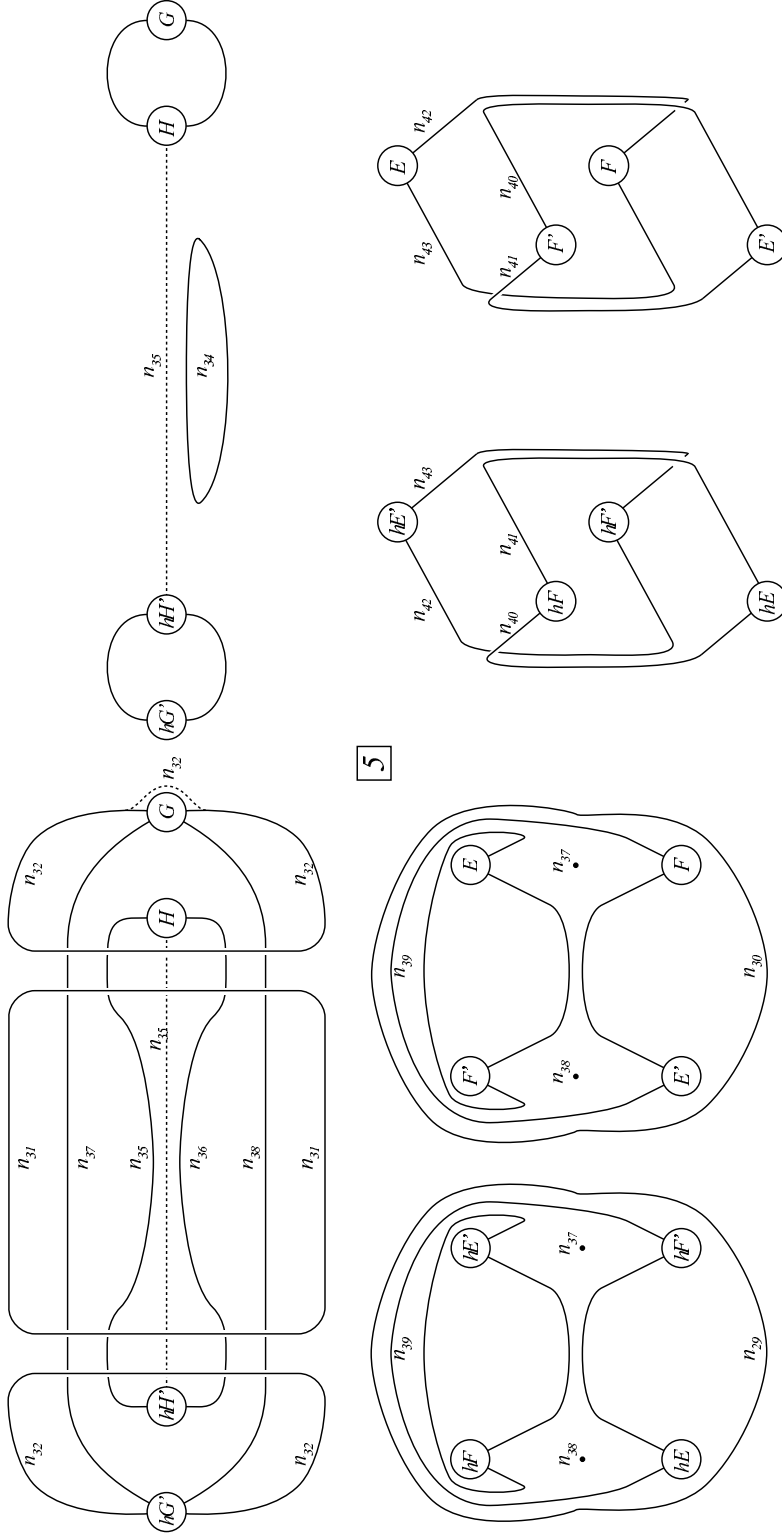

Figure 21: Step 5

n_{33}, n_{27}, n_{28} cancel $G'hG, hJhJ', II'$ respectively	
n_{31} rises in part above x_1x_2 -plane, spans surface like an arched roof that contains its parallel circle	
n_{32} rises in part above x_1x_2 -plane, slides over $G'hG'$ and off G into dotted position	
n_{35} isotopes into dotted position	
both branches of n_{39} are isotoped by rotating by 180° around the axis joining their endpoints — the dots representing where n_{37} and n_{38} cross these planes show they do not interfere with the isotopy	
n_{31}, n_{32}, n_{34} cancel a 3-handle; n_{29} and n_{30} can be separated from the rest of the diagram by pulling them in the x_1 -direction, then each cancels a 3-handle	

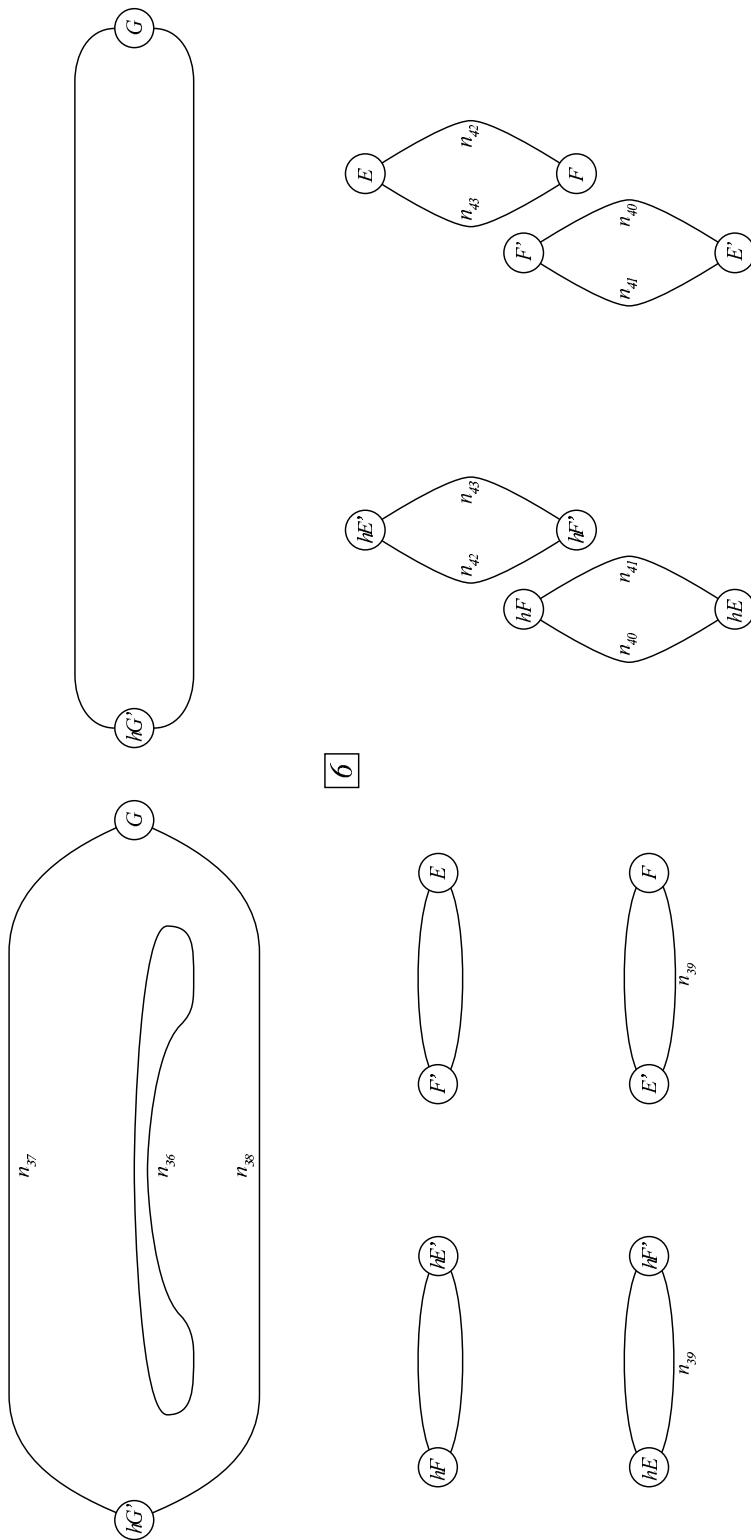

Figure 22: Step 6

n_{35} cancels HhH'	
n_{37} and n_{38} isotoped up and down, respectively	n_{40}, n_{41}, n_{42} and n_{43} are isotoped along the S^2 's so they lie, along with their parallel circles, in planes parallel to the x_1x_3 -plane — note that n_{37} and n_{38} do not interfere with this in their new position
n_{36} cancels a 3-handle	

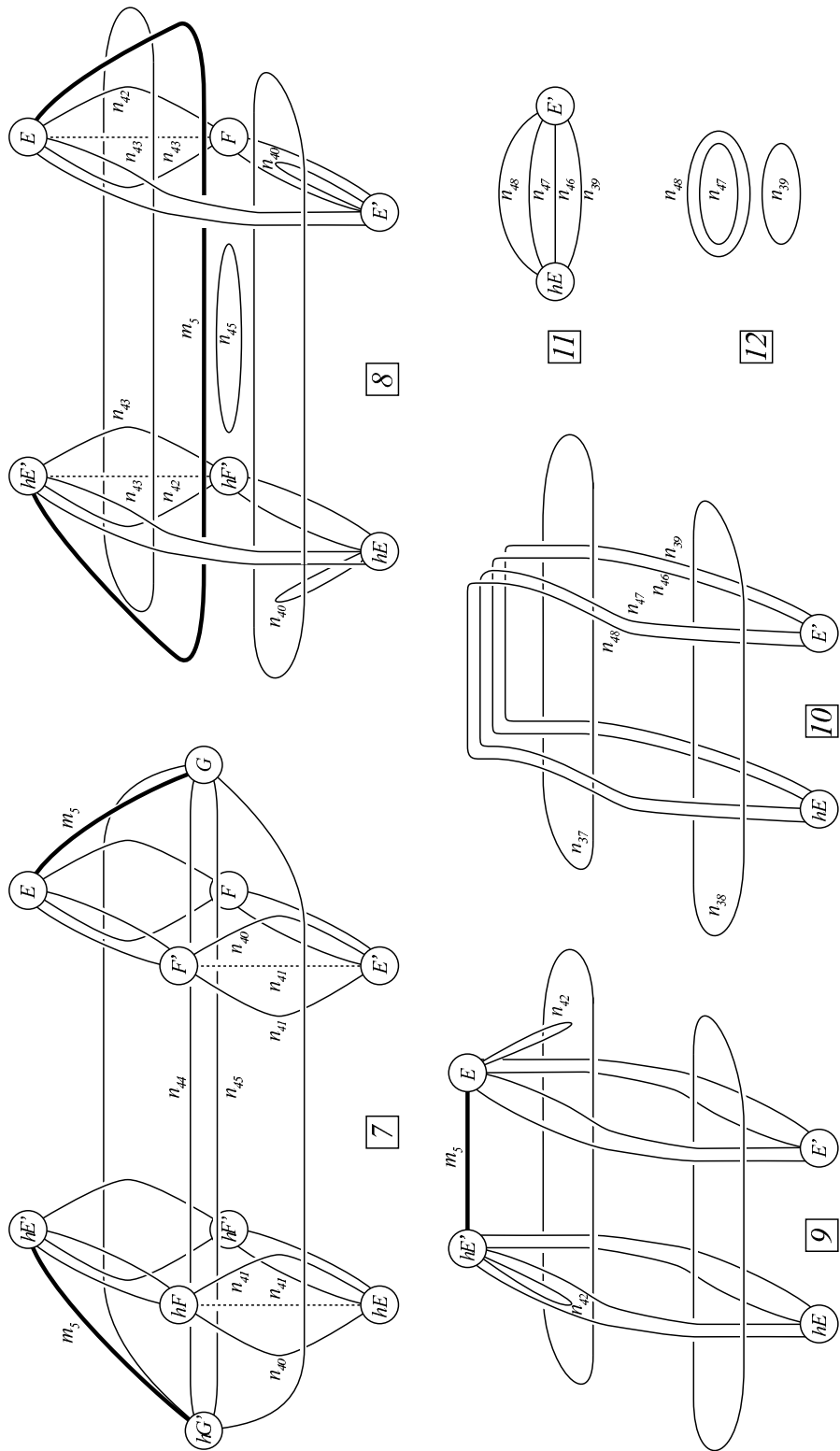

Figure 23: Steps 7–12

<p>n_{41} isotopes to dotted positions parallel curve of m_5 can be chosen right above m_5</p>	<p>n_{41} cancels $F'hF$, n_{44} cancels GhG' n_{43} isotopes to dotted positions n_{40} slides over $E'hE$ and off hE, then cancels 3-handle n_{45} cancels 3-handle</p>
<p>m_5 isotopes n_{43} cancels FhF' n_{42} slides over EhE' and off E, then cancels 3-handle</p>	<p>m_5 cancels EhE' n_{37} and n_{38} can be separated from the diagram and cancel 3-handles</p>
<p>n_{39}, n_{46}, n_{47} and n_{48} can be isotoped so they all lie in a plane, along with their parallel curves n_{46} cancels $E'hE$ n_{39}, n_{47} and n_{48} cancel 3-handles</p>	

References

- [1] S. Bleiler and C. Hodgson. Spherical space forms and dehn filling. *Topology*, 35(2):809–833, 1996.
- [2] George K. Francis. *A topological picturebook*. Springer-Verlag, 1987.
- [3] R. Gompf and A. Stipsicz. *4-manifolds and Kirby Calculus*, volume 20 of *Graduate Studies in Mathematics*. AMS, 1999.
- [4] D. Ivanišić. Hyperbolic structure on a complement of tori in the 4-sphere. *Adv. Geom.*, 4(1-2):119–139, 2004.
- [5] D. Ivanišić, J. Ratcliffe, and S. Tschantz. Complements of tori and klein bottles in the 4-sphere that have hyperbolic structure. *Algebraic & Geometric Topology*, 5:999–1026, 2005.
- [6] J. Ratcliffe. *Foundations of hyperbolic manifolds*. Springer-Verlag, 1994.
- [7] J. Ratcliffe and S. Tschantz. The volume spectrum of hyperbolic 4-manifolds. *Experiment. Math.*, 9(1):101–125, 2000.
- [8] Robert Riley. Discrete parabolic representations of link groups. *Mathematika*, 22(2):141–150, 1975.
- [9] Norbert Wielenberg. The structure of certain subgroups of the Picard group. *Math. Proc. Cambridge Philos. Soc.*, 84(3):427–436, 1978.